

**MAINE GUIDE
to
ENERGY EFFICIENT
RESIDENTIAL
CONSTRUCTION**

A MANUAL OF ACCEPTED PRACTICES

Fourth Edition

Maine State Energy Program

Maine Public Utilities Commission

18 State House Station

Augusta, Maine 04333-0018

(207) 287-3349

January 2006

[This page intentionally left blank]

The Maine Guide to Energy Efficient Residential Construction: A Manual of Accepted Practices

First published in 1980 by the Maine Office of Energy Resources
This edition published in 2006 by the Maine State Energy Program, Public Utilities Commission
#18 State House Station, Augusta, Maine 04333-0018

The details presented in this book are schematic design ideas and are not meant to be working construction drawings. The State Energy Program advises you to consult an architect, engineer, designer or builder for complete construction details. The Maine State Energy Program and its contractor, R.J. Karg Associates, make no statement, representation, claim or warranty with respect to the methods described or illustrations contained in this publication. For questions about this publication, or other energy-related information, write to the Maine State Energy Program, Maine Public Utilities Commission, State House Station 18, Augusta, ME 04333-0018.

The Maine Guide to Energy-Efficient Residential Construction: A Manual of Accepted Practices was funded by a grant from the U.S. Department of Energy and printed by the Maine State Energy Program under Fund 013, Agency 65A, ORGN 3007, Appropriation 012.

First Edition (West River Communications)

First printing: January 1980

Second printing: February 1992

Third printing: August 1996

Second Edition (R.J. Karg Associates)

First printing: November 1997

Third Edition (R.J. Karg Associates)

First printing: November 2002

Fourth Edition (R.J. Karg Associates)

First printing: February 2006

[This page intentionally left blank]

Contents

Acknowledgments	v
Introduction	vii
Part 1. Summary of Maine's Model Building Energy Code	1
1. Adoption of the Maine Model Building Energy Code	3
2. Buildings that Must Comply	3
3. Methods of Compliance	3
4. Exempted Buildings	3
5. The Maine Model Building Energy Code and the International Energy Conservation Code	5
Part 2. Siting and Initial Design Considerations	7
1. Solar Orientation	7
2. Prevailing Weather Conditions and Landscaping Considerations	8
3. Suntempering and Passive Solar Design	9
4. House Layout	10
5. Green Design	11
Part 3. Important Considerations for the Design Phase	13
1. Insulation	13
2. Air Leakage	15
Materials Used for Reducing Air Leakage	18
3. Indoor Air Quality	19
ASHRAE Standard 62.2-2003 and Mechanical Ventilation	21
Radon	22
4. Moisture Control	24
Alternative Methods of Wall Construction	27
5. Ventilating Building Cavities	28
Roof Ventilation	28
Crawl Space Ventilation	30
6. Windows	30
7. Doors	32
8. Heating Considerations	32
Equipment Installation and Maintenance	34
Sizing Heating Systems	34
9. Energy-Efficient Appliances	34
10. Energy-Efficient Lighting	36
11. Promising Technologies	36
Fuel Cells	36
Photovoltaics	37
Hybrid Systems	37
Advances in Heat Pumps	37
12. Advantages of Building an Energy-Efficient Home	38

Contents (continued)

Part 4. Recommended Construction Practices	39
1. Foundations	39
Exterior Foundation Insulation	40
Interior Foundation Insulation	43
Slab-on-Grade Foundation	45
Crawl Space Foundation	48
2. Floors Over Unheated Spaces	48
3. Walls	51
4. Roof Details	55
Insulated Flat Ceilings	55
Insulated Sloped Ceilings	57
5. Structural Insulated Panel Systems	63
6. Installing Windows and Doors	65
7. Other Measures to Reduce Air Leakage	66
8. Commissioning	67
Appendixes	
A. Heat Loss Calculations	71
B. R-Values of Common Building Materials	75
C. Comparing Heating Fuel Costs	76
D. Glossary	78
E. For More Information: References	81
F. Performance or Tradeoff Method of Compliance with REScheck ..	82

Acknowledgments

The Maine State Energy Program gratefully acknowledges the substantial contributions made by those who participated in the publication of this *Maine Guide to Energy-Efficient Residential Construction: A Manual of Accepted Practices*.

Among those whose efforts made this publication possible are:

First edition

Alexander T. Wilson, President of West River Communications, Inc., who reviewed the Maine Office of Energy Resource's original *Manual of Accepted Practices* and revised, expanded, and improved its contents;

Donald McCollester, of General Art, who provided the technical illustrations under contract to West River Communications, Inc.

Second and third editions

Andrew P. Wynn, of the Energy Division of the Office of Economic and Community Development, who coordinated the revision, and provided technical assistance. The second and third editions were dedicated to Andy;

John Merrill, of the Energy Division, who provided editorial and proof reading;

Bruce Olson, of the Energy Division, who provided technical and production assistance;

Chris Carroll, of the Energy Division, who provided editorial and proof reading;

Rick Karg, of R.J. Karg Associates, who revised the first and second editions.

Fourth edition

Michael Mayhew of the Maine State Energy Program who provided technical and editorial assistance.

Denis Bergeron of the Maine State Energy Program who provided technical and editorial assistance.

Rick Karg, of R.J. Karg Associates, who revised the third edition.

[This page intentionally left blank]

Introduction

This guide has been developed to acquaint builders with the Maine Model Building Energy Code and to present to them techniques that they can use to achieve the required efficiency levels. It goes beyond simply presenting Code's requirements. It is designed to serve as a construction reference for builders by addressing a wide range of issues, materials and techniques relevant to the construction of energy-efficient buildings. Because of its location, Maine has varied climatic conditions—damp coasts, dry mountains, high winds, seasonal temperature variations of up to 130°F and daily temperature variations of as much as 50°F—which present a challenging environment for the building of durable, energy-efficient houses.

Although written for builders, this guide is not intended to be a how-to manual of construction practices for the first-time builder. It is intended to complement existing skills and knowledge and is written with the presumption that the user is fully familiar with conventional construction practices, building materials, and job-site safety. For those who are not skilled builders, it is highly recommended that this guide be used as a companion to other more comprehensive construction publications. Terms that may not be familiar to builders or homeowners are printed in **boldface** when they first appear and/or when they are defined in the text. They are also defined in the Glossary.

The details and techniques in this manual should serve as examples only. Wherever practicable, more than one way is suggested for meeting the efficiency levels required by the Maine Model Building Energy Code. The construction details and techniques set forth in this guide are not intended to be the only options available to a builder. It is recommended, instead, that they be used as a basis for the development of still better building techniques, and to augment existing practices.

Building design and construction are ongoing processes which evolve to meet changing economic, practical and aesthetic requirements. It is hoped that builders, through the use of this guide, will incorporate into their building practices the latest and best energy-efficient methods.

This *Maine Guide to Energy Efficient Residential Construction* was developed with the help of builders, architects and engineers. It represents a consensus of opinion on energy-efficient construction practices at the time of its writing. Because advances in the field of energy-efficient construction and the development of new products are continuous, it is to be expected that this guide will need to be revised periodically. Suggestions on how it could be made more useful or instructive will be welcomed by the Maine State Energy Program, Public Utilities Commission, State House Station 18, Augusta, ME 04333-0018, (207) 287-3349.

This document was funded by a grant from the US Department of Energy. It is available in alternative formats upon request (207) 287-3349.

[This page intentionally left blank]

Part 1. Summary of Maine's Residential Model Building Energy Code

The law creating the Maine Model Building Energy Code and its discretionary adoption by Maine towns became effective July 27, 2005.

The prescriptive method of compliance is summarized in **Figure 1** and **Table 1**. These prescriptive standards are designed to be simple and easy to follow.

The Code also allows compliance by a

component performance approach using a free software tool called REScheck™. Please see **Appendix F** for details of this alternate means of compliance.

The required efficiency levels were developed to be cost-effective for Maine's climate and to achieve energy use levels in accordance with national standards.

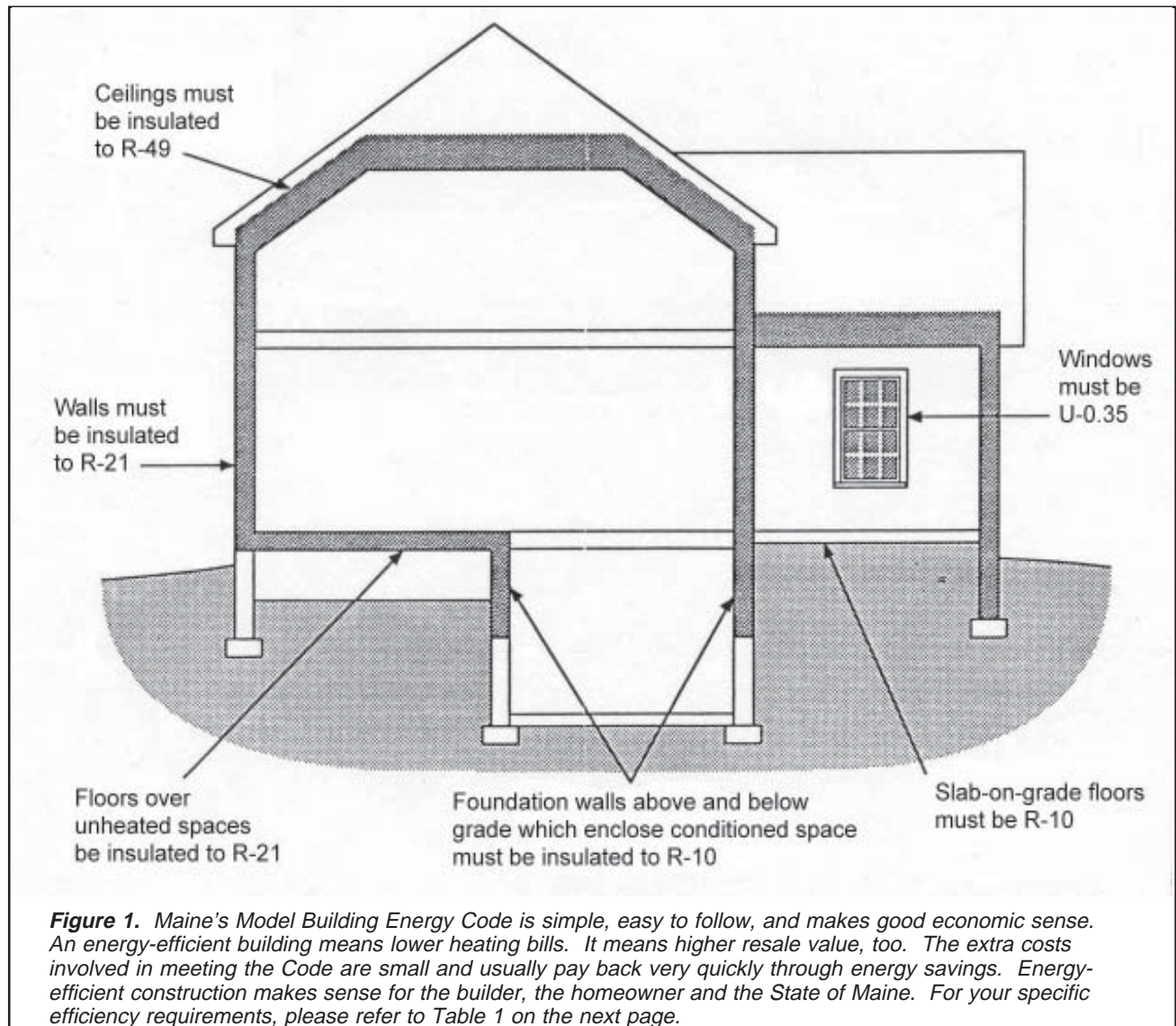

TABLE 1
Efficiency Levels Required by Maine’s Model Code¹

All locations except Aroostook County

	<i>Glazing U-factor (windows or doors)</i>	<i>Ceiling R-value</i>	<i>Wall R-value</i>	<i>Floor R-value</i>	<i>Basement Wall R-value to Footing</i>	<i>Slab on Grade R-value and (depth)²</i>	<i>Crawl Space Wall R-value</i>	<i>Furnace or Boiler Efficiency, AFUE³</i>
Package #1	.35	38	19	21	10	10 (4')	20	80
Package #2	.40	38	21	21	10	10 (4')	20	82
Package #3	.40	49	21	21	10	10 (4')	20	80

Aroostook County

	<i>Glazing U-factor (windows or doors)</i>	<i>Ceiling R-value</i>	<i>Wall R-value</i>	<i>Floor R-value</i>	<i>Basement Wall R-value to Footing</i>	<i>Slab on Grade R-value and (depth)²</i>	<i>Crawl Space Wall R-value</i>	<i>Furnace or Boiler Efficiency, AFUE³</i>
Package #1	.35	38	19	21	10	10 (4')	20	85
Package #2	.40	38	21	21	10	10 (4')	20	86
Package #3	.32	49	21	21	10	10 (4')	20	83

¹ The specified R-value refers to the rated R-value of the insulation only, not taking into account reductions in the system R-value due to framing members, and not including the added system R-value for other building components (sheathing, siding, drywall, etc.) and air films.

² Slab on grade insulation “feet” designation includes the sum of rigid insulation installed downward and then under the slab, or downward and then away from the slab or foundation wall. Make sure to protect insulation from possible frost action.

³ For AFUE (Annual Fuel Utilization Efficiency) values of certified furnaces and boilers, refer to *Consumers’ Directory of Certified Efficiency Ratings for Heating and Water Heating Equipment*, available at www.gamanet.org.

Component Performance Compliance Alternative - an alternative method of complying is available with the use REScheck™ software, available free at www.energycodes.gov/rescheck. See **Appendix F** for details.

1. Adoption of the Maine Model Building Energy Code

Nothing in the Maine Model Building Energy Code law requires a town to adopt the Code. However, if a town without an energy code decides to adopt one, then it must adopt the Maine Model Building Energy Code.

A town that had an energy code in effect before the effective date of the Maine Model Building Energy Code may continue to use that code for as long as it wishes. If such a town replaces its energy code, it must adopt the Code.

Because of this town-by-town adoption of the Code, it is recommended that builders, designers, owner builders, and others in the construction industry check with town officials to determine the local energy code requirements.

Even if a town has not adopted the Maine Model Building Energy Code, it is recommended that all residential buildings are designed and built to comply with the Code. It just makes good sense to do so.

2. Buildings that Must Comply

When a town adopts the Model Building Energy Code, the following guidelines apply.

Residential buildings that enclose conditioned space must comply with the Code. The standards applicable for compliance are the *International Residential Code* (IRC-2003), chapter 11; the *International Energy Conservation Code* (IECC-2003), chapters 4, 5, and 6; and *Ventilation and Acceptable Indoor Air Quality in Low-Rise Residential Buildings* (ASHRAE 62.2-2003). Residential buildings include detached one- and two-family dwellings and multifamily dwellings that are not more than three stories in height.

The types of residential dwellings that must comply are new buildings; additions; and some alterations, renovations, and repairs. Refer to the Maine law, Chapter 920, for more information.

If you are a builder or designer, you should encourage your clients to follow Code even though it may not be required in the town in which you are building. If you are an owner-builder, you should follow the Code. Buildings constructed according to the Code will save

thousands of dollars in energy costs over their lives and better construction practices will increase the building's resale value.

3. Methods of Compliance

Compliance with the Maine Model Building Energy Code may be achieved by one of several easy methods.

First, you may build according to the efficiency levels in **Table 1**. Select the appropriate climate zone in Maine, select one of three packages that meet your needs, and satisfy the requirements for each building component. This prescriptive approach to compliance requires no calculations or computer software.

Second, you may follow the energy requirements in the appropriate table of the International Energy Conservation Code (IECC), 2003 edition. Of course, to do so you will have to obtain the IECC-2003 document. See **Appendix E** for ordering information.

Finally, you may obtain a copy of REScheck™ software and use it to ensure compliance with the Maine Model Building Energy Code. This software is available free at www.energycodes.gov/rescheck. See **Appendix F** for details.

4. Exempted Buildings

There are some residential building types that are not required to comply with the Maine Model Building Energy Code.

First, unheated camps or cabins intended for summer use only are not required to comply.

Second, the Code does not apply to the construction of log homes.

Finally, the Code does not apply to single-family, owner-built homes. The law makes it clear that this exemption only includes a home actually constructed by the owner who will use the building as a residence. A person who merely supervises the construction or contracts with another to supervise construction, is not considered an owner builder.



Figure 2. County map of Maine. The Maine Model Building Energy Code divides the state into two zones. One zone is Aroostook county and the other zone includes all other counties.

5. The Maine Model Building Energy Code and the International Energy Conservation Code

The Maine Model Building Energy Code for residential buildings is based on the 2003 International Energy Conservation Code (IECC) for residential buildings. In other words, if a residential building complies with the 2003 IECC, it complies with the Maine Model Building Energy Code. Virtually all state energy codes are based on a particular version of the IECC.

Although the Maine Energy Code is based on the 2003 IECC, there are a few unique features of the Maine version. First, Maine lawmakers adopted *Ventilation and Acceptable Indoor Air Quality in Low-Rise Residential Buildings* (ASHRAE 62.2-2003) along with the 2003 IECC. This indoor air quality and ventilation standard was published by the American Society of Heating, Refrigerating and Air-Conditioning Engineers (ASHRAE).

Second, although the 2003 IECC divides Maine into three climate zones, Maine lawmakers adopted the simpler 2004-IECC two-climate zone designation for Maine. Aroostook county is one of these two climate zones and all the other Maine counties make up the other zone. Although this might at first seem confusing, it actually makes compliance less complex.

Finally, as mentioned in the previous section of this chapter, three types of residential buildings are exempted in Maine.

Energy-Efficient Site Design

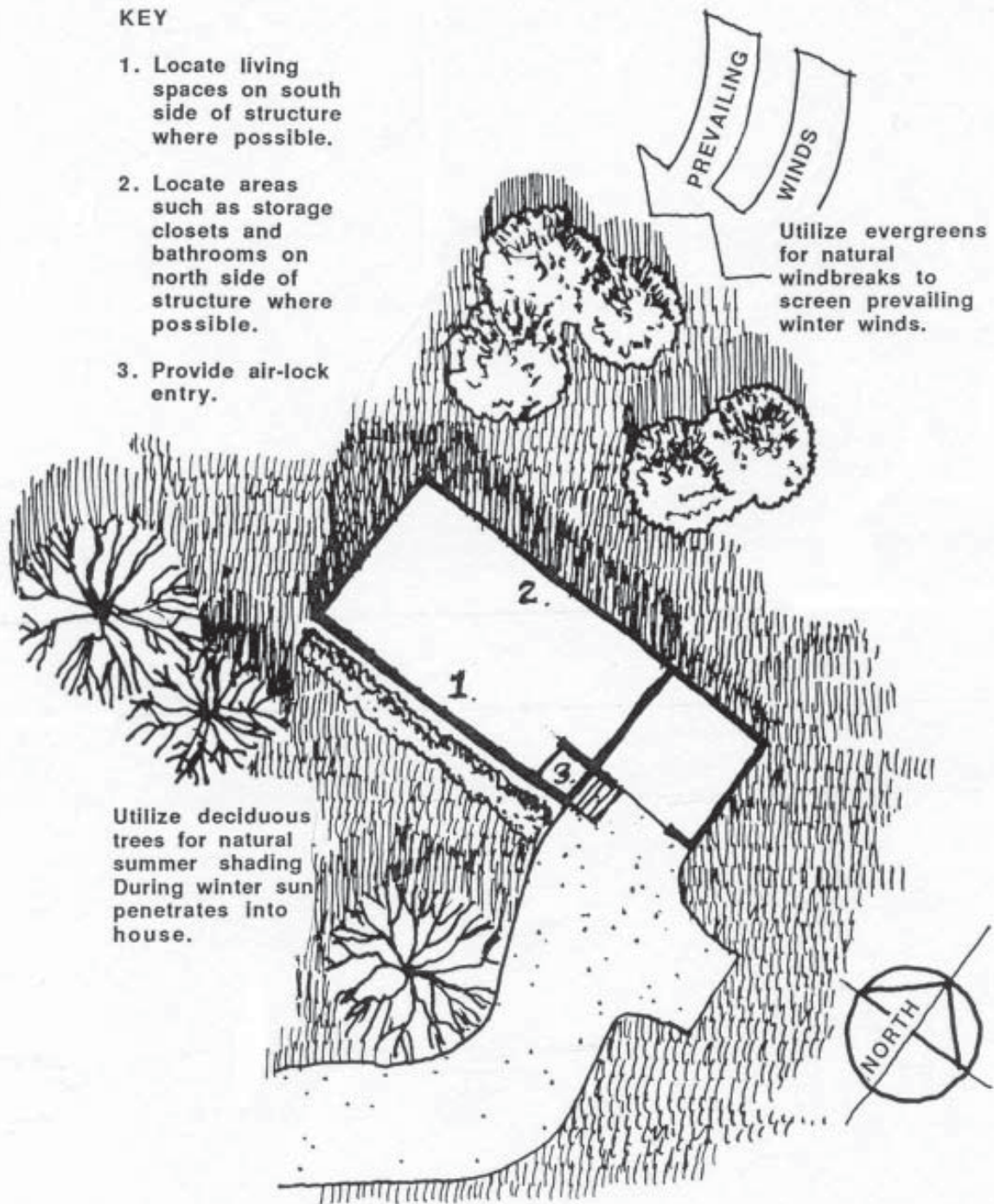

Part 2. Siting and Initial Design Considerations

There is a lot more to building an energy-efficient house than insulation, air-leakage control, and an efficient heating system. Planning should start with a careful evaluation of the building site and how it will influence your design and the performance of the structure. You should consider solar exposure for passive solar heating, prevailing weather conditions, landscaping possibilities to provide natural wind protection and summertime shading, and water drainage.

1. Solar Orientation

Suntempering and **passive solar** heating can reduce heating costs while boosting comfort and making a living space more exciting. With either approach (described below), the house must be oriented to allow maximum use of south-facing glass. Ideally, a long wall of the house should face true south, but variation of up to 30° east or west will not significantly affect solar heating performance (see **Figure 3**).

To determine the solar orientation of a building site, use a compass and be sure to correct for the **magnetic declination** for your location. The declination is the difference between true north and where the compass points. In Maine, magnetic declination varies from 16° to 22° west, meaning that true north is actually west of magnetic north. Likewise, true south is east of magnetic south. Magnetic declination is shown on any USGS topographic map. The Energy Programs Division of the Maine Public Utilities Commission publishes a guide for determining the solar potential of a building site. Call and ask for the *Maine Solar Primer*.

To determine whether nearby trees, mountains or buildings will block the solar exposure of a new house, you will need to check **sun angles** at various times of the day and year. As shown in **Figure 4**, the summer sun rises much higher in the sky—has a greater altitude—than during the winter. With passive solar design, the south-facing glass should to be exposed to the sun during as

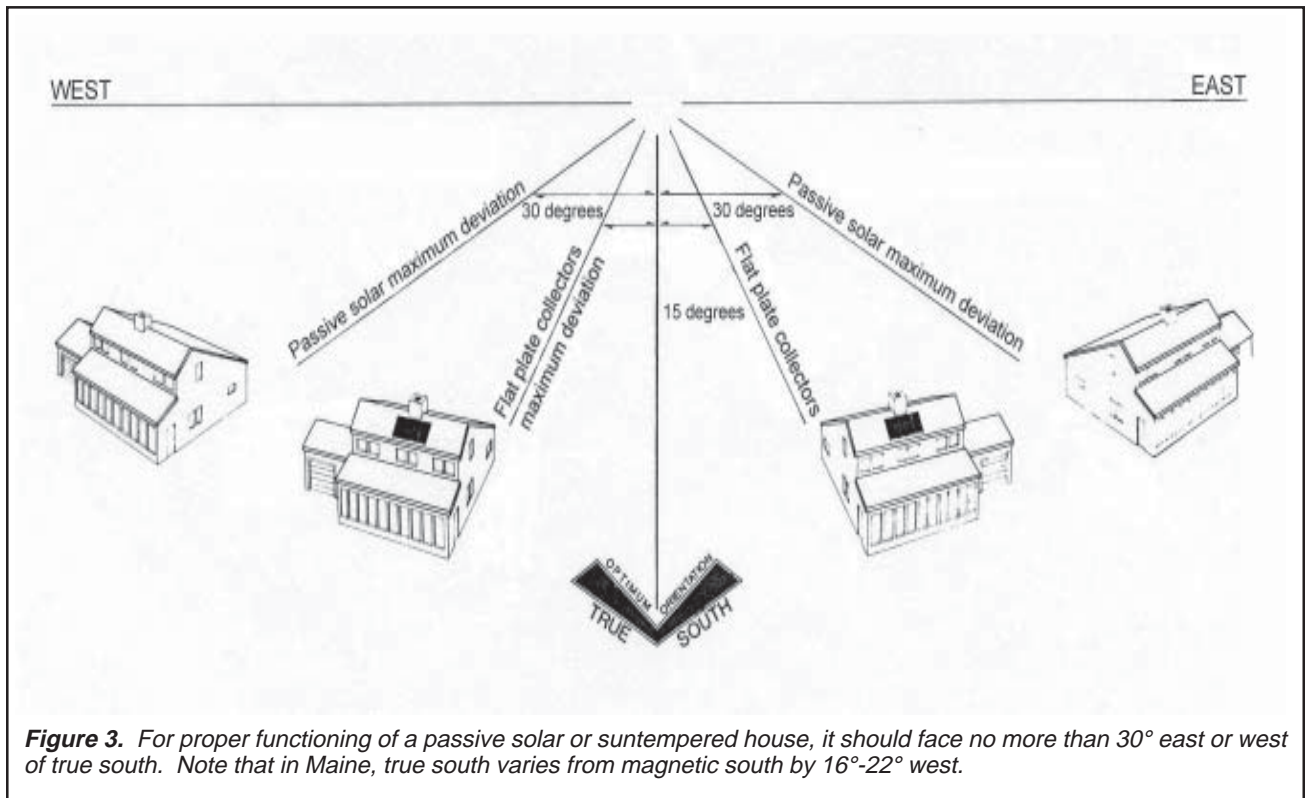
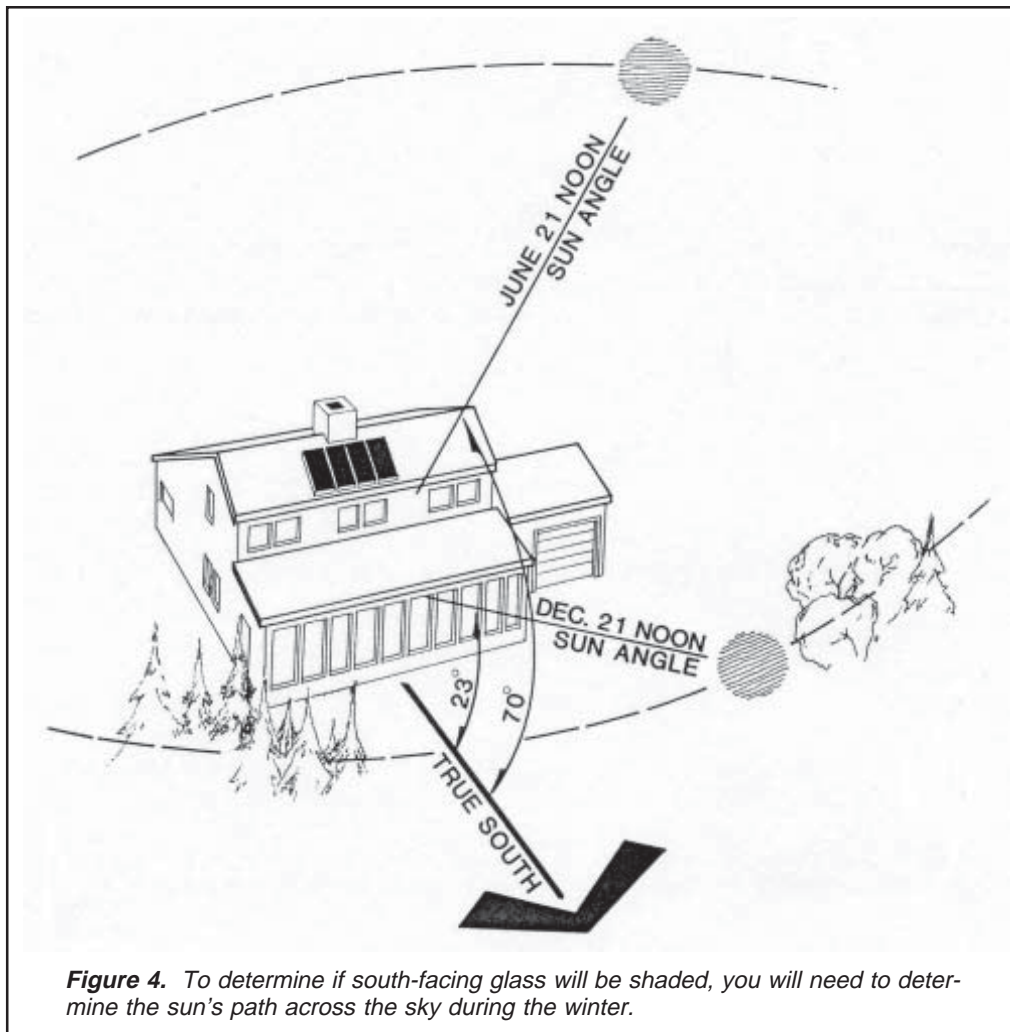

Figure 3. For proper functioning of a passive solar or suntempered house, it should face no more than 30° east or west of true south. Note that in Maine, true south varies from magnetic south by 16°-22° west.



much of the day as possible during the winter months when the sun is low in the sky. Simple tools and kits are available for determining the precise path the sun follows across the sky at different latitudes (see references).

2. Prevailing Weather Conditions and Landscaping Considerations

At some building sites, it makes sense to determine what the local weather patterns are, particularly on coastal and mountain locations where high winds can significantly affect comfort and heating costs. In most of Maine, the prevailing winter winds are from the north and west, but this is not always the case, especially along the coast. Check with a local weather station or nearby airfield for information on prevailing winds in your area, or visit the site and ask neighbors about wind conditions.

If the winter winds are primarily from one direction, it makes sense either to locate the house on a portion of the building site where it will be protected from those winds, or to plan on planting a windbreak (see **Figure 5**). Conifers (pine, spruce, fir, hemlock) are best for a windbreak, because they do not lose their leaves in the winter. Local topography can also be used in protecting the house from winter winds. By setting the house into a south-facing hillside, for example, winds from the north will tend to rise up over it.

To provide solar exposure on the south, most trees should be removed. A few tall deciduous trees (most species, but not all, lose their leaves in the fall) close to the house will be all right, especially if the lower branches are removed to allow the winter sun to penetrate. When leafed out in summer, these tall trees will help block the hot summer sun, reducing the possibility of unwanted

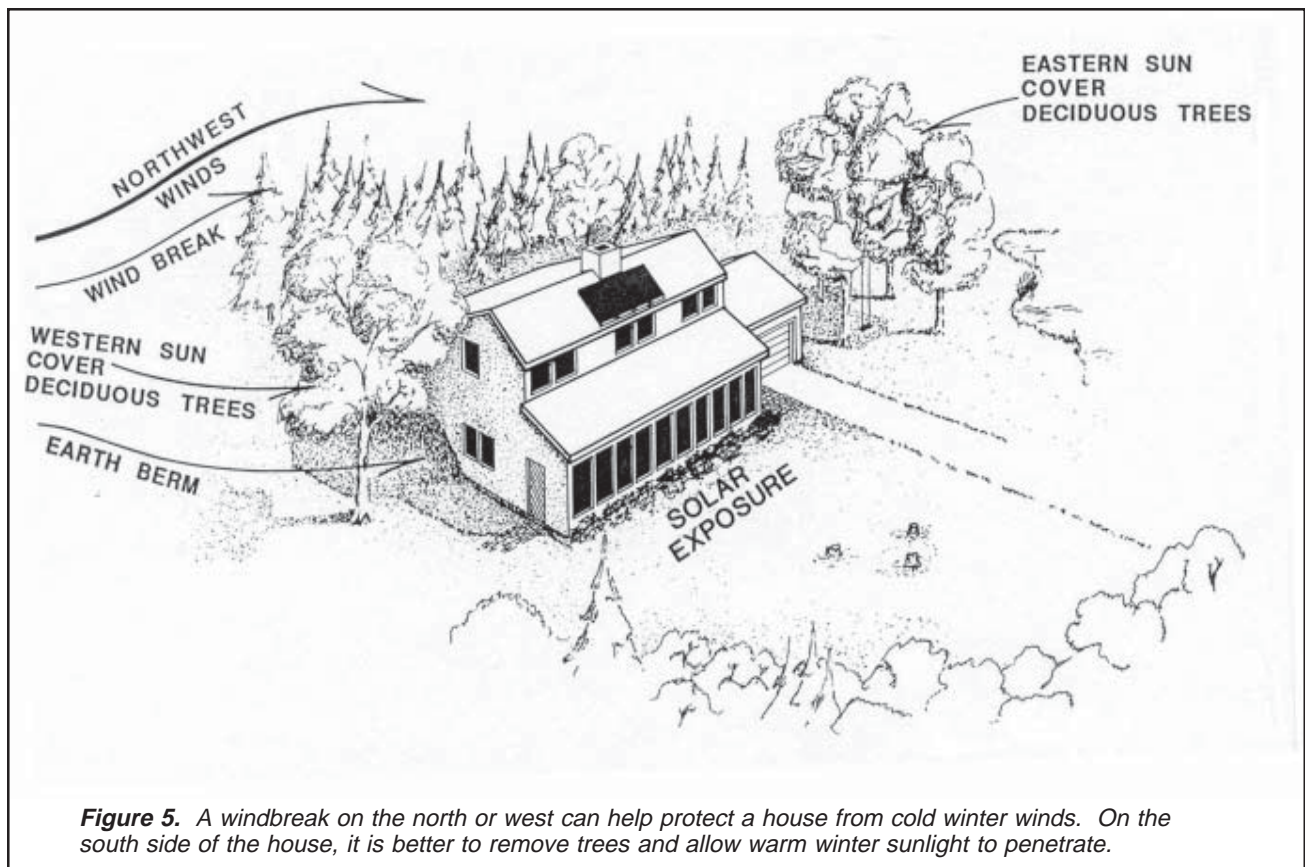

Figure 5. A windbreak on the north or west can help protect a house from cold winter winds. On the south side of the house, it is better to remove trees and allow warm winter sunlight to penetrate.

heat gain. On the east and west sides of the building, it often makes sense to leave some deciduous trees to block the summer sun. This is particularly important on the west, where afternoon sun can be quite hot and uncomfortable in the summer. If trees are not already present on the west, it makes sense to plant some, both to provide afternoon shading and to protect the house from cold winter winds (**Figure 5**).

Of course, all landscaping plans should take into account the potential views from the house. If the house overlooks a lake on the north, the importance of the view might outweigh the energy benefits of planting a windbreak or the energy penalty of incorporating a large area of glass.

3. Suntempering and Passive Solar Design

Suntempering design strategies collect and use the sun's energy without specialized mechanical means of distributing or storing it. In general, suntempering refers to the simple addition of south-facing glass (within 30° of true south)

without incorporating materials to store the collected heat. To prevent daytime overheating on sunny winter days, the south glass area in suntempered houses is usually limited to 7 percent or less of the floor area. Suntempered houses can be designed and constructed by builders and architects who have no specialized knowledge of solar design.

Passive solar systems, on the other hand, incorporate more sophisticated designs to provide for thermal storage and a larger south-facing glass area. Using passive solar techniques generally requires specialized knowledge of passive solar design.

There are a number of different types of passive solar heating systems, the two most common being direct gain and solar sunspaces with thermal storage (**Figure 6**).

Direct gain is simply more elaborate suntempering. High-density materials are incorporated into the design to absorb and store the solar heat energy transmitted through south-facing glass. Common heat storage materials include masonry fireplaces, brick walls, tile floors

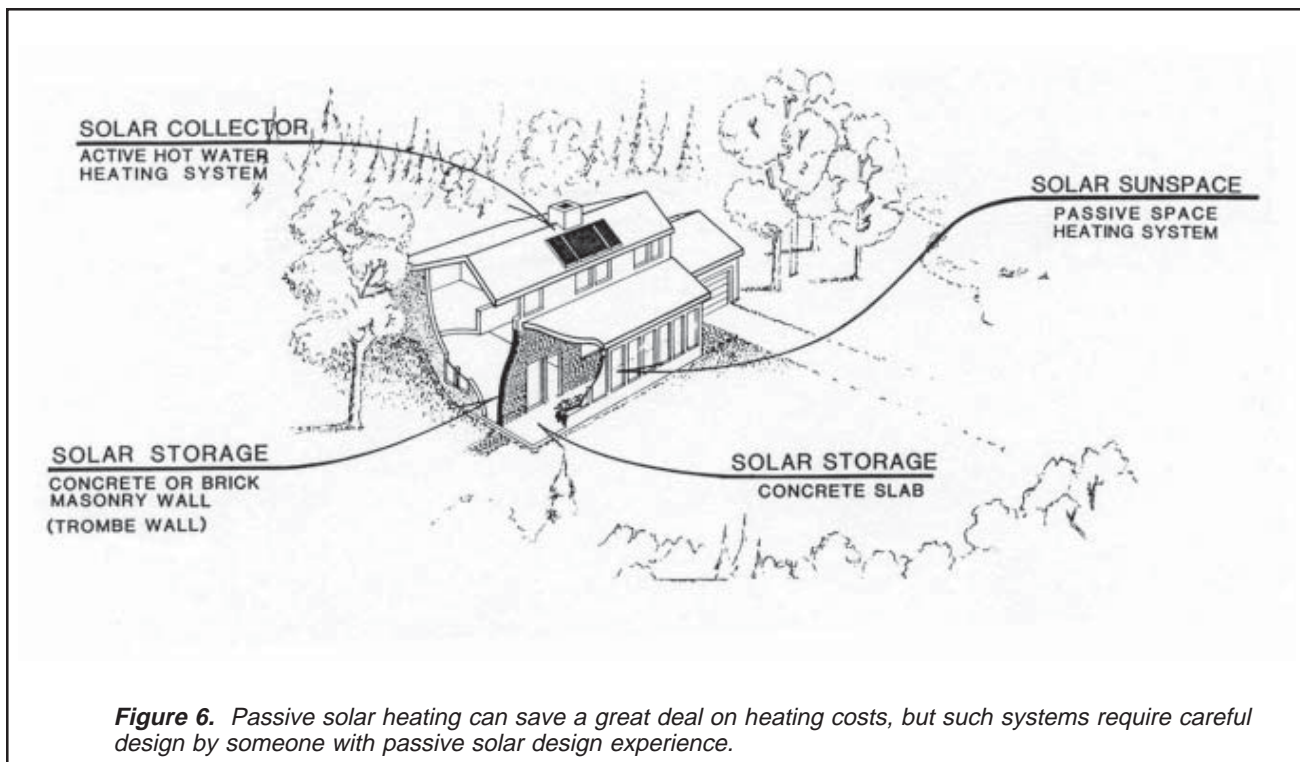

and specially designed containers of water. To effectively absorb solar heat energy, dark surfaces are recommended. Wood and drywall can also provide heat storage, but larger areas of these materials are required because they cannot absorb and store as much heat. To be most effective, high-density heat storage materials should be exposed to direct sunlight for at least part of each day during the heating season.

Properly designing a passive solar heating system involves careful calculations and an understanding of solar geometry. Faulty design can result in overheating during the day and cool indoor conditions at night. If you have not had experience with passive solar design, it may make sense to hire the services of a designer with such experience.

A **solar sunspace** is an addition to a house with a means of storing heat and distributing heat from the sunspace into the house. To prevent the sunspace from robbing heat from the house at night, there should be a way to seal it off from the house, such as closable connecting doors.

When considering solar energy possibilities, keep in mind the possible installation of solar collector panels in the future. For example, while solar water heating panels may not be installed

during the initial construction, you may want to design the building in a way that will allow their addition at a later date. This could include a south facing roof with room for solar panels and a properly located utility room with adequate space to accommodate a storage tank.

4. House Layout

Room layout can have a significant effect on energy use in the home. Many factors are involved in determining which living spaces should be located where, but when possible, it makes sense to locate the spaces used during the daytime toward the south where natural daylight (and passive solar heat) can be utilized. Bedrooms usually don't need as much daytime light, so locations on the east, west, or north side of the house make sense. Many people prefer east-facing bedrooms because they like awakening to the rising sun. Try to keep storage areas, utility rooms, closets and other spaces that don't need windows toward the north, so that north-facing windows, which admit no significant solar heat, can be kept to a minimum.

During the initial planning, try to provide for an air-lock entry for the most often used entrance to the house. This will cut down on air leakage

while providing a place to take off boots and hang coats. The air-lock entry should have tight-fitting doors, both to the outside and to the living space. The actual space can be within the heated envelope of the house or outside of it, but if it is inside the primary building envelope, it does not require heating. For best performance, the air-lock entry should be insulated both on its exterior walls, ceiling, and on its common walls with the house. Try to locate entry doors in sheltered locations—sheltered either by the house itself, or by natural features of the site, such as vegetation.

When any living space is located over a garage (*a practice many building scientists discourage because of indoor air pollution concerns*), think about the use of this space. If the garage ceiling is properly insulated (R-21 minimum), sealed with an air barrier and has a vapor retarder, as it should, the space above the garage will be no less comfortable than other parts of the house. But if there is concern about the quality of insulating or sealing, consider locating less important space above a garage, such as a storage area or guest room.

5. Green Design

Green design and building goes beyond energy-efficient construction by reducing the building's impact on natural resources and the environment and providing healthy and comfortable living environments. At the roots of green design are environmental sustainability, building durability, and protection of health.

Green building standards often consider landscape design for low water use and microclimate control, site proximity to public transportation, indoor air pollution control, construction durability, waste management, occupant health and safety, and educating homeowners about proper maintenance of the home.

Homeowners benefit from green homes in many ways, including low energy bills, higher resale value, lower cost of ownership, and the knowledge that their home uses natural resources in a sustainable way.

Designers and builders benefit from green buildings with increased profits, improved customer satisfaction, and the knowledge that

their buildings make a minimum impact on the environment. Of course, building green also indicates to prospective clients that a builder is concerned about the environment and the welfare of clients.

Although the scope of the Maine Model Building Energy Code does not extend beyond energy efficiency and acceptable indoor air quality, standards for green design and building are now available to the public. Please refer to the references section of this publication for resources.

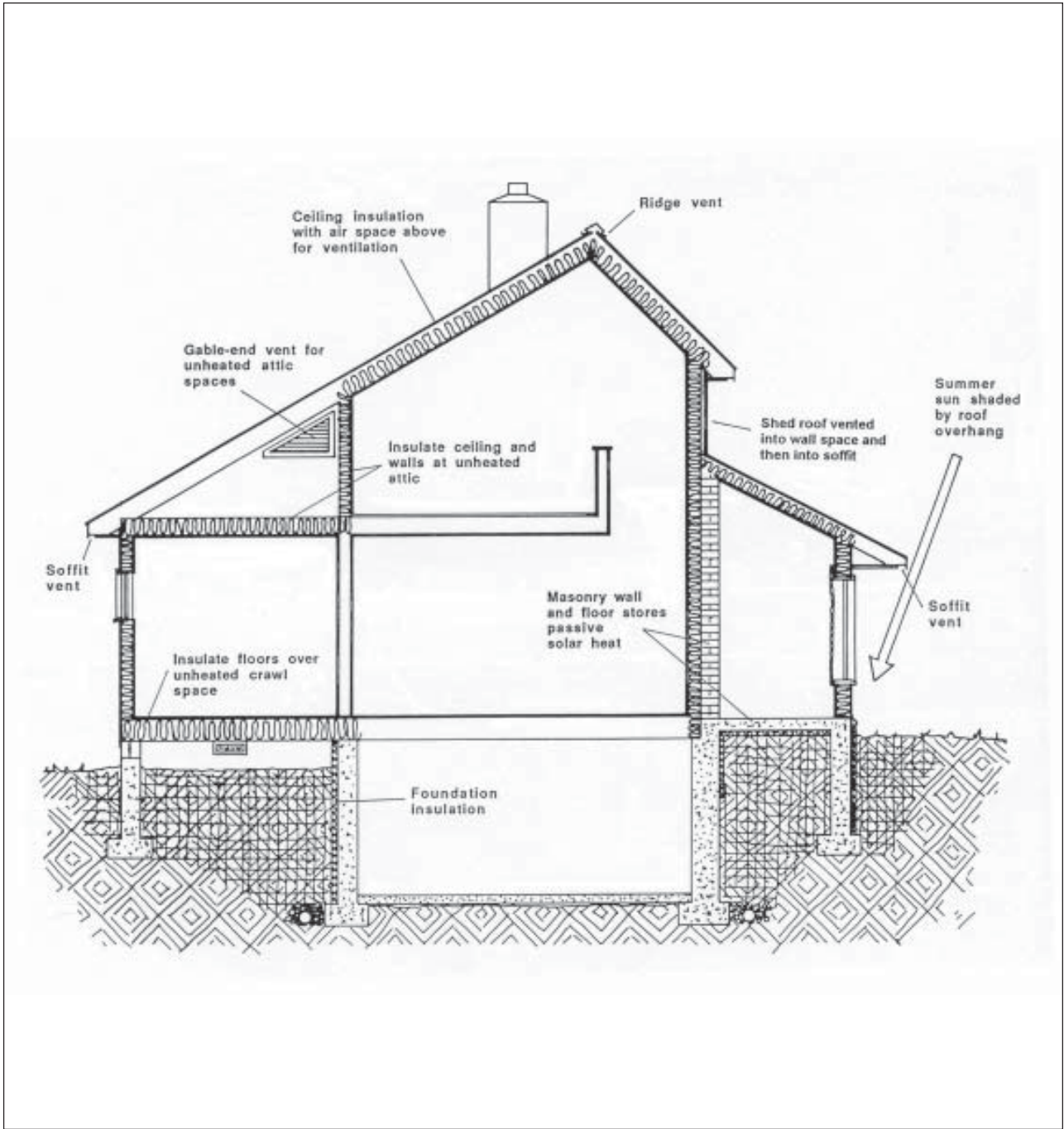

Part 3. Important Considerations for the Design Phase

During the past thirty years, interest in energy efficiency has dramatically changed the way houses are built. New materials and advanced construction techniques have reduced energy consumption as much as fourfold, but these changes have greatly increased the complexity of houses.

As a consequence, designers and builders must have knowledge of many varied topics, including heat flow, insulation materials, moisture migration, indoor air quality, and awareness of the latest products and technologies. They must know how the different components of a house interact, enhancing comfort and reducing operating costs on the positive side, but potentially causing moisture problems and callbacks on the negative side. With today's tighter, more energy-efficient houses, it is extremely important the designers and builders understand that *houses, along with their mechanical equipment and occupants, are systems, with one part interacting with another. Understanding the relationships between cause and effect within this system is critical.*

This section addresses a wide range of important topics relating to new home construction. A full understanding of these topics will ensure proper implementation of the construction details presented later in this guide.

1. Insulation

Heat always flows from warmer areas to colder areas. During the winter months, all the heat that is used to keep a house warm is eventually lost through the building envelope. How quickly that heat escapes depends on two factors: the difference in temperature between the inside and outside of the building, and how effectively the building envelope slows the flow of thermal energy. Installing insulation is the primary strategy used to slow down the transmission of heat

through walls, ceilings and floors. The resistance to heat flow of insulating materials is measured by the **R-value**. Insulation R-values are based on very specific testing requirements of the Federal Trade Commission and must be listed on all commercially sold insulation materials.

The required insulation levels for walls, ceilings, floors and foundations under the Maine Model Building Energy Code are presented in **Part 1** of this manual, along with special definitions that apply. Specific construction details to satisfy those requirements are described in **Part 4, Recommended Construction Practices**.

Common insulation materials and their properties are listed in **Table 2**. Insulation materials may be divided into two categories: cavity-fill and rigid board. Included among cavity-insulation materials are fiberglass (batts or loose-fill), mineral fiber (batts or loose-fill), cellulose (loose-fill or wet-spray), and several specialized installed-in-place products, such as Icynene®. Rigid board insulation materials include extruded polystyrene (such as Dow Styrofoam®), expanded polystyrene (beadboard), poly-isocyanurate, and polyurethane.

For wall, ceiling and floor applications, fiberglass batt insulation is used most often. Batts are available in a wide range of thicknesses and widths to meet different framing and thermal requirements. In flat ceilings and closed wall cavities, loose-fill cellulose is very common and usually less expensive than fiberglass. In walls, **wet-spray cellulose**, though relatively uncommon, is gaining popularity.

When high insulation levels are required and/or a thinner wall or cathedral ceiling is desired, rigid board insulation is typically used—often in conjunction with batt or loose-fill insulation. Foil-faced poly-isocyanurate and

TABLE 2
Common Insulation Materials

TYPE OF INSULATION	R-value per inch (range)	Where used	How Installed	Resistance to:				Max. Temp.	Available in:
				Water Abs.	Moisture Damage	Direct Sun	Fire		
BATTS, ROLLS									
Fiberglass	3.17 (3.0-3.8)	wall, floor & ceiling cavities	Fitted between studs, joists or rafters	2	1	1	2	180°F	Batts and rolls Widths - 11" to 48"; Thicknesses 1" -13" Available unfaced, with kraft paper facing or aluminized paper facing.
Rock Wool	3.17 (3.0-3.7)	Wall, floor & ceiling cavities	Fitted between studs, joists or rafters	2	1	1	1	>500°	Batts and rolls Widths - 11" to 24"; Thicknesses - 3" to 8"
LOOSE, POURED OR BLOWN									
Fiberglass	2.2 (2.2-4.0)	Ceiling cavities	Poured and fluffed, or blown by machine	2	1	1	2	180°	Bags: 15-30 lb.
Rock wool	3.1 (2.8-3.7)	Ceiling cavities	Poured and fluffed or blown by machine	2	1	2	2	>500°	Bags: 25-35 lb.
Cellulose	3.2 (3.1-3.7)	Ceiling cavities	Blown by machine	4	4	2	3	180°	Bags: 15-30 lb.
Perlite	3.0 (2.8-3.7)	Hollow concrete block	Poured	3	2	1	2	200°	Bags
RIGID BOARD									
Expanded Polystyrene (Beadboard)	4.0 (3.6-4.4)	Wall, ceiling, roof	Glued, nailed	4	2	4	4	165°	Boards: 2'x8', 4'x8'; other sizes Thicknesses: 1/4" to 10" Special facings, T&G edges available
Extruded Polystyrene (Styrofoam®) (Foamular®)	5.0	Foundation, roof	Glued, nailed sub-slab, wall, ceiling, roof	1	1	4	4	165°	Boards: 2'x8', 4'x8' Thicknesses: 3/4"-2" Special facings, coatings, T&G edges available
Isocyanurate (Thermax®) (Hi-R®)	6.0 (5.6-7.7)	Wall, ceiling, roof	Glued, nailed	2	1	4	4	200°	Boards: 4'x8' Thicknesses: 1/2"-4"
Rigid Fiberglass	4.4 (3.8-4.8)	Wall, ceiling, roof, foundation wall	Glued, nailed	2	1	1	2	180°	Boards: 4'x8' Thicknesses: 1"-3" Available with various facings
INSTALLED IN PLACE									
Wet-Spray Cellulose	3.5 (3.0-3.7)	Wall cavities	Sprayed in open cavities	4	3	2	3	165°	K-13 formulation Installed by contractor only
Polyurethane	6.2 (5.8-6.8)	Wall & ceiling cavities, roofs	Foamed in open cavities	1	1	4	4	165°	Different formulations available Generally installed by contractor Cannisters and cans available for small sealing applications.
Icnene	3.6	Wall & ceiling	Sprayed in open cavities	1	1	4	3	200°	Installed by certified contractors

* 1 = EXCELLENT 2 = GOOD 3 = FAIR 4 = POOR

polyurethane provide the highest R-values per inch—from R-5 to R-6 per inch, although these R-values may drop somewhat after “aging.”

For below-grade exterior foundation insulation applications, extruded polystyrene or rigid fiberglass are generally recommended. The other rigid insulation materials will absorb moisture and lose effectiveness.

There are a number of foam-in-place cavity-fill insulation materials for use in wall and ceiling cavities. These are usually more expensive than conventional materials, but in certain applications, they may be a better alternative. Two examples of foam-in-place insulations are polyurethane and Icynene®.

Icynene® is installed by spraying liquid components onto an open wall, crawl space or ceiling cavity. The expanding foam provides an air barrier, but is not a vapor retarder. The excess expanded material is easily trimmed off before drywall is installed.

Blown-in-Blanket System® (BIBS) is a patented system that uses a combination of insulation (often loose fiberglass) mixed with an adhesive. This mixture is blown into open-stud walls behind netting.

For more information on insulation materials, refer to the booklet *Insulation Facts*, published by the Maine State Energy Program (207-287-3349).

2. Air Leakage

Air leakage is the uncontrolled movement of air into and out of buildings. It both brings cold air into the house and allows warm air to escape. It is the second major heat loss type, the first being **surface or transmission heat loss** which is reduced by adding insulation. Air leakage typically accounts for 30 to 50 percent of the total heat loss. *By carefully planning during the design phase and paying attention to details during construction, air leakage can be greatly reduced.* In fact, with proper attention to air barriers, tight-fitting windows and doors, and careful sealing at sills and around all building envelope penetrations, air leakage will often be low enough to require mechanical ventilation. This is not a disadvantage.

It is important to understand that tight houses that use fans to supply fresh outdoor air are more energy-efficient and have better indoor air quality than looser houses that do not require this mechanical ventilation.

Potential air leaks in new construction are shown in **Figure 7**. To keep leakage to a minimum, follow the guidelines listed below, most of which are keyed to the illustration:

1. Build in a vestibule or air-lock entry at the most often used entry door. This allows the exterior door to be closed before the door to the house is opened to reduce air leakage through the open door. This entry also provides for the very functional space known as the mudroom.
2. Minimize the placement of electrical outlets on exterior walls (within electrical code guidelines), and carefully seal those receptacles to the air barrier. Special airtight boxes for receptacles are available that can be easily sealed to the air barrier. Install gaskets under the electric outlet and switch plates located on exterior walls.
3. Install only high-quality, pre-hung, factory-weatherstripped windows. Look for windows that have rated air leakage levels that comply with ASTM (American Society of Testing Materials) E-283, “Standard Test Methods for Rate of Air Leakage Through Exterior Windows, Curtain Walls and Doors.” The air leakage must be tested under a 25 mph wind speed.
4. Install only high-quality, pre-hung, factory-weatherstripped metal, fiberglass or wood entry doors. Metal and fiberglass doors are much less likely than wood doors to warp and become sources of air leakage. Look for doors with integral weatherstripping and adjustable thresholds.
5. During window and door installation, carefully seal around jambs with foam backer rod, caulk, or expanding foam sealant. Expanding foam sealant provides the tightest seal. Apply a generous bead of expanding foam sealant to continuously “weld” the window jamb to the rough opening. Be careful not to apply too much foam sealant, especially if it is a high-expanding type, as it could make window operation difficult. The suggested practice is to fill only one-half to two-thirds of the cavity depth. During framing, be sure to build a large enough rough opening to allow proper sealing ($\frac{3}{8}$ "- $\frac{1}{2}$ " on all sides). See the discussion of foam sealants below. Additionally, it is very important to properly flash all windows and doors.
6. Do not install recessed lights below unheated attic spaces or in other spaces that are connected to cold

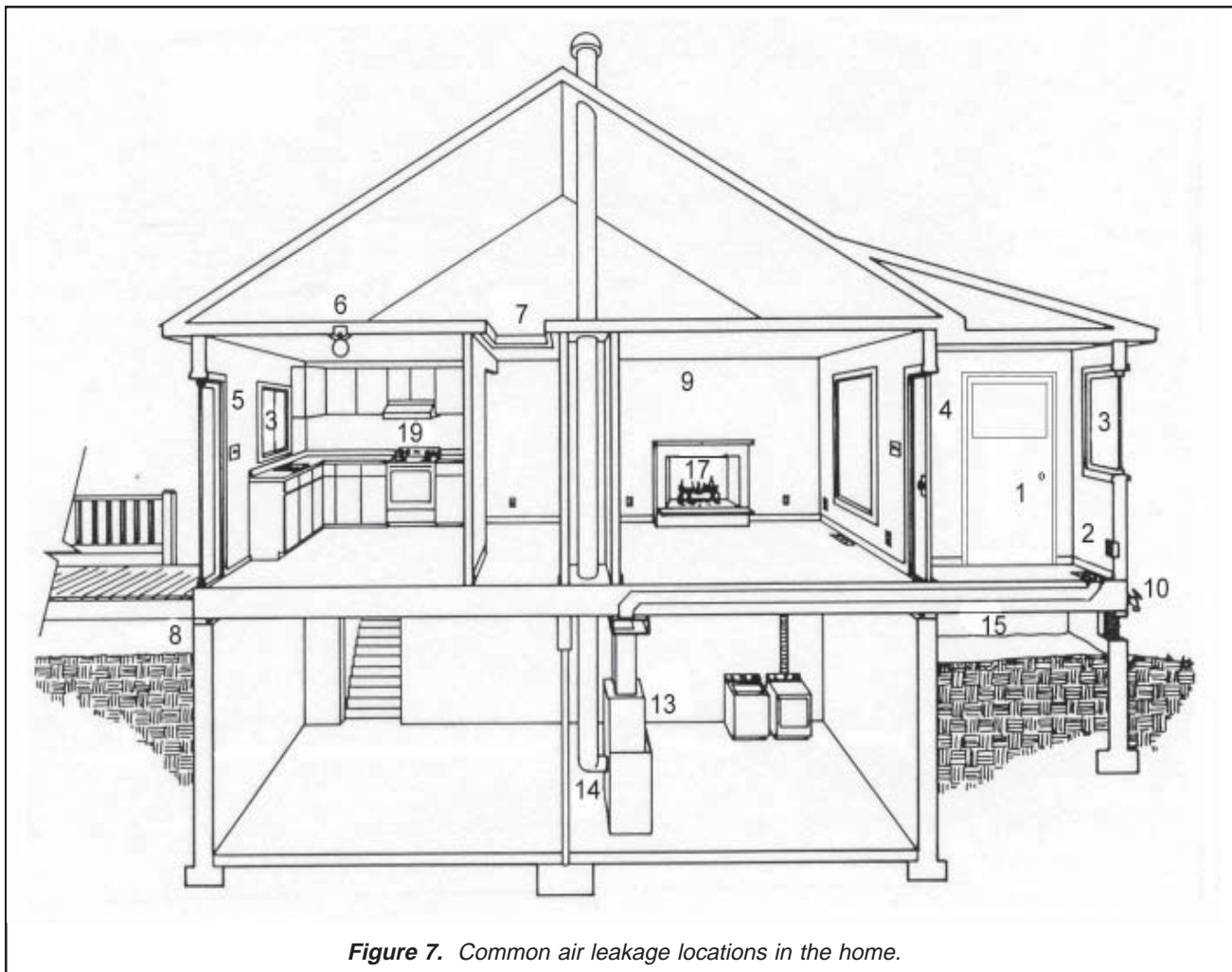

Figure 7. Common air leakage locations in the home.

outdoor air. If recessed lights must be installed, make sure they are Type-IC so that they can be fully covered by insulation.

7. For access to an unheated attic, install a tight-fitting, well-insulated attic hatch. If properly weatherstripped and insulated units are not available, you may have to add weatherstripping and insulation yourself. With pull-down stairs, install an insulated box cover that can be lifted off when climbing the stairs. Consider adding an attic access door through an exterior gable-end wall rather than one through the ceiling.
8. Install a sill sealer between the sill and foundation. An open-cell foam sill sealer allows both very tight compression and excellent air blockage at larger gaps.
9. Install a continuous **air barrier** toward the inside of all exterior walls and insulated ceilings. Edges and overlaps should be taped or caulked. Be especially careful with the air barrier installation at problem construction areas such as drop ceilings over bathtubs, over kitchen cabinets and at heated attic knee walls. If the bathtub is to be installed

along an exterior wall before drywall is installed, be sure that the air barrier is not punctured, and seal the edges of the tub carefully.

10. Seal cracks around all pipes, vent stacks, wires and conduits penetrating the exterior walls and ceilings. Also seal penetrations in plumbing or wiring chases that extend between floors. Use high-quality caulk or foam sealant (see discussion below). This helps create a continuous air barrier.
11. During framing, caulk the plates to the subfloor as wall sections are tilted into place. After the drywall is installed, caulk the joint between the bottom edge of drywall and the floor on all walls before installing baseboard.
12. Install a **house wrap** underneath the exterior siding. This house wrap will offer good temporary protection from the weather and help make the building slightly more airtight. The house wrap should be as continuous as possible. Tape it to the sheathing at the top and bottom and at all overlapping joints. Also tape it to the framing at all window and door openings. Use a high-quality contractor's tape. If using plywood sheathing, a

house wrap is not as important, but it will help block air flow at the plywood's joints and is still recommended by many experts.

13. If possible, install only **direct-vent** (sometimes referred to as **sealed combustion**) space-heating and water-heating equipment. These appliances draw their combustion supply air directly from the outdoors through a dedicated pipe. Because of this feature, they pose no risk of **backdrafting** harmful combustion gases into the house.
14. Install a code-approved fireproof seal around any flues penetrating the walls or floors.
15. If the ducting for the heating system must pass through unheated space, fully seal and insulate the ducts and the duct joints with approved **duct mastic** (do not rely on duct tape for sealing ducts; it breaks down quickly).
16. Do not use joist or wall cavities for ducts because they cannot be tightly sealed. Cold air may be pulled in from unheated spaces through the framing, or warm air passing through the ducts may be lost to unheated spaces. Use only hard ducted distribution.
17. Fireplaces are generally *not recommended* in energy-efficient houses because of their inherent inefficiency and the heat loss associated with them. However, if a fireplace is to be installed, do the following:
 - a. Install a tight-fitting damper at the top of the masonry fireplace flue.
 - b. Install high-quality, tight-closing glass doors on the front of the fireplace.
 - c. Install combustion air inlet ducts that direct air to the fireplace's combustion area. It is best if these ducts have tight-fitting dampers.
 - d. With masonry fireplaces that extend through exterior walls, construct a thermal break at the wall penetration.
 - e. Seal chimney and flue penetrations through insulated ceilings and roofs in accordance with local fire codes. An air space is generally required next to the masonry. This should be sealed at the top and bottom of the penetration with 26-gauge (minimum) galvanized steel and a noncombustible, high-temperature sealant.
18. If installing a wood stove, seal chimney penetrations through insulated floors, walls and ceilings (use insulated flue pipe as required by code for these penetrations). If possible, select a wood stove with an outside-air supply connection.
19. Install kitchen and bathroom exhaust fans with tight-fitting backdraft dampers. In place of standard bathroom exhaust fans, you can use heat recovery ventilators (see the section on indoor air quality below), which are better from an energy standpoint. These devices should not be used for ventilating kitchen ranges. Timers can be used on the fans to control their operation time. Carefully seal duct penetrations through insulated walls and ceilings with caulk and/or foam sealant.
20. Provide tight-fitting insulating covers for through-the-wall air conditioners and air conditioning sleeves.

The air leakage rates for houses are measured in **air changes per hour (ACH)**. To accurately estimate air leakage rates, the house must be tested with a blower door.

A blower door test involves setting up a specialized fan in an exterior door opening of the house, closing all other exterior doors and windows, and then using the fan to depressurize the house. The rate of air flow through the blower door required to maintain a specific negative pressure in the house is expressed as a CFM₅₀ value (Cubic Feet per Minute at 50 Pascals of pressure difference between the inside and outside of the house) or is converted to air changes per hour. Generally, a trained technician is hired to perform the blower door test and interpret the results.

By following the construction practices recommended in this guide, the air leakage rate should be no more than about 0.4 ACH. With very careful attention to the measures described above, the air leakage rate can be kept as low as 0.1 ACH.

All new homes need whole building ventilation installed according the ASHRAE Standard 62.2-2003, *Ventilation and Acceptable Indoor Air Quality in Low-Rise Residential Buildings*. This is addressed in the Indoor Air Quality section, pages 19-24.

An advantage of blower door testing is that the technique can be used to find air leaks. With the blower door operating, you or a blower door specialist can look for leaks. Walk around each room holding your hand up to detect air currents. Because the house is under fairly high negative pressure, any leaks will be very noticeable.

Materials Used for Reducing Air Leakage

Building a tight house that will remain tight necessitates using high-quality materials that are installed properly. Select caulks, gasketing materials, air barriers, vapor barriers and other materials that are rated for a long life—twenty to fifty years.

To function properly, a caulk must be able to expand and contract with the seasonal movement of the materials (wood, for example, expands in the summer months and shrinks in the winter). Some products maintain much greater flexibility

over time than others. High-quality silicone, siliconized latex, and polyurethane caulks, for example, will maintain excellent flexibility for more than twenty years, while oil-based caulks will dry out and lose all flexibility after just a few years.

The properties of common caulking materials are shown in **Table 3**. When you are comparing caulks at a building supply center, it may be difficult to distinguish one type of caulk from another by their labels. If you cannot determine

TABLE 3
Common Caulking Materials

<i>Generic Product</i>	<i>Cost</i>	<i>Useful Life</i>	<i>Joint Movement</i>	<i>Comments</i>
Oil-based	Low	3-5 years	Very poor - 1%	Poor adhesion to wet surfaces. Considerable shrinkage. Generally not recommended. Should be painted.
Butyl Rubber	Low to Medium	8-12 yrs.	Fair - 5-10%	Good adhesion to masonry and metal; poor to wet surfaces. May be stringy during application. Long curing time before paintable.
Acrylic Latex	Low to Medium	3-10 yrs.	Poor - 2%	Use only for interior applications on joints between similar materials. Easy to use; cleans up with water; paintable.
Siliconized Acrylic Latex	Medium	10-20 yrs.	Fair - up to 10%	Silicone greatly improves product over standard acrylic latex. Easy cleanup and painting; minimal shrinkage. Considerable variation between brands relative to percent silicone.
Silicone	High	20-50 yrs.	Highest - 50%	Excellent flexibility. Good adhesion to most materials. Effective over very wide temperature range. Easy application. Most are not paintable. May not bond well to all woods.
Polyurethane	High	20-30 yrs.	Good - 25%	Excellent adhesion to most surfaces. Very good performance. Paintable. Cleanup may be difficult. Used by professionals for years; only recently has it become widely available.
Ethylene Copolymer	Medium	> 20 yrs.	Good - 25%	Good adhesion to most materials; good flexibility; paintable. Good general-purpose caulk.

what type of caulk it is, read the label and look for the properties you want, such as a long lifetime, a guarantee of quality, paintability, and ability to bond to the appropriate substrates. Price is often a good indicator of quality—the better, longer-lasting caulks cost more.

When you apply caulk, remember that proper bonding of any caulk depends on the surface to which it is being applied. Surfaces should be structurally sound and free of dust, grease, mold, mildew and moisture.

Expanding foam sealants have simplified the sealing around window and door frames, at wiring penetrations, and at other large gaps. These sealants are available in cans or large canisters. Some manufacturers supply specialized application guns for use with the larger cans. Both low-expanding and high-expanding foam sealants are available. In general, the low-expanding types are preferable for all but the largest holes. Using low-expanding foam sealant around windows and doors is especially important, because the high-expanding sealants can push and warp the jambs, making windows and doors difficult to operate.

Low-expanding foam sealants are easier to use than high-expanding types. Examine the literature on the foam sealant carefully. If they are unavailable as a stock item at building supply stores, low-expanding foams can generally be ordered by the store or purchased directly from the manufacturer.

In addition to caulks and foam sealants, **foam gaskets** and **backer rod** can also be used to reduce air leakage. High-quality closed-cell or polymer-saturated open-cell foam gaskets should be used under sill plates. Foam backer rods (round in cross-section) can be used for sealing deep or wide cracks, or for providing a backing for caulk in deep cracks. Open-cell foam gaskets can be used for sealing between exterior wall sections, plates and the subfloor.

Air barriers are also important defenses against air leakage. This barrier should be installed on the interior (warm) side of wall and ceiling insulation, if possible. The air barrier blocks air flow into wall and ceiling cavities, where lower temperatures could cause condensation of the water vapor carried by air. *To be effective, all air*

barrier joints and tears should be sealed with tape or non-hardening caulk.

A **vapor barrier** (permeance of 0.1 or less) or **retarder** (permeance greater than 0.1, but less than 10) have a different function than that of the air barrier. Whereas the air barrier is meant to stop the flow of air and its contained water vapor through walls and ceilings, vapor barriers and retarders are meant to retard the *diffusion* of moisture through walls, ceilings, and floors. Often the air barrier and the vapor barrier are the same material, such as 6-mil polyethylene.

As an alternative, some builders use taped and gasketed drywall as the air barrier and special paint primer applied to the inside of the drywall as a vapor barrier. Please see the discussion of **Moisture Control** below for more information.

3. Indoor Air Quality

With all houses, but especially with tight ones, it is important to keep indoor air quality in mind. Too little fresh air coming into the house causes indoor air pollutants to build up. Indoor air pollution comes from building materials, furnishings, the activities of the homeowners (such as smoking, cooking and cleaning), combustion appliances, high humidity, and even from the ground around and under the house. Some of the more common indoor air pollutants and their sources are listed in **Table 7**.

While many of the potential health effects of indoor air pollutants are long-term and difficult to attribute to a particular pollutant, some individuals have allergies to particular chemicals or suffer from multiple chemical sensitivity (MCS), which makes them reactive to a wide range of common household pollutants. Some experts claim that MCS is becoming more common.

It is important for builders to have a general understanding of indoor air quality issues, know how to protect against problems, and be aware of what to do if difficulties are identified by homeowners. There are four levels of action that can be taken to deal with indoor air pollution problems.

First and most importantly, potential pollution sources should be kept out of the house. This can be done by installing only direct vent or sealed combustion appliances; avoiding products contain-

ing formaldehyde, such as medium density particleboard (commonly used in kitchen cabinets); and designing the foundation to keep radon out.

Second, if materials that emit pollutants are used to construct the house, you may be able to seal these material surfaces to lower or eliminate pollutant emissions. For example, kitchen cabinets can be sealed with a high-quality finish to effectively lock the formaldehyde in and keep it out of the household air.

Third, it is often advisable to spot-ventilate near pollution sources. Fans should be installed in

kitchens to exhaust cooking odors and fumes. Bathroom fans should be installed to ventilate odors and water vapor. A window in a bathroom is not an adequate substitute for an operating exhaust fan. If a room is planned as a hobby room or darkroom, install a ventilation system.

Fourth, and finally, general ventilation is recommended in new houses to ensure an adequate supply of fresh outdoor air. The American Society of Heating, Refrigeration and Air Conditioning Engineers (ASHRAE) recommends the operation of whole-building mechanical ventila-

TABLE 4
Common Indoor Air Pollutants

<i>Pollutant</i>	<i>Source</i>
Formaldehyde	Plywood (particularly interior grade), particleboard, paneling, other laminated wood products. Carpeting, drapes, clothing and other synthetic products. Indoor combustion sources.
Volatile organic compounds	Cleaning products, pesticides, fabric softeners, deodorizers. Synthetic materials used in interior construction and decorating.
Poisons	Pesticides, rodent poisons, roach sprays, flea powder. Sawing and sanding dust from pressure-treated wood. Dust from older materials with lead paint (e.g., recycled doors).
Asbestos	Usually no longer used in new products. In older homes, used as an insulation on heating pipes and as a siding material. In new construction, only found in a few recycled building materials.
Combustion gases (carbon monoxide, sulfur dioxide, nitrogen dioxide)	Unvented kerosene heaters. Improperly vented combustion appliances. Gas ranges that are improperly adjusted. Cigarette smoke. Wood stoves and fireplaces leaking smoke into living space.
Airborne biological agents (bacteria, mold, viruses, dust mites, fungi)	Illness in the household. High humidity (above 50% relative humidity), damp basements. Improperly installed heating system ductwork.
Radon	Soil or bedrock surrounding the house in most of Maine. Well water.
Water vapor	Household activities (showering, bathing, cooking). Exterior water sources (improper drainage, roof leaks). Unvented combustion appliances.

tion when the house is closed up for winter heating or summer cooling. See the next section for suggested ventilation flow rates.

Some indoor air pollution sources are primarily a concern only for the first month or two after construction is completed (paint, varnish and adhesive fumes, and high water vapor levels from drying concrete and wood, for example). Dealing with these pollutants may require higher-than-normal ventilation for a period of several weeks or months following construction. This can be accomplished by opening windows or operating **heat recovery ventilators** or exhaust fans at higher settings than would otherwise be required.

ASHRAE Standard 62.2-2003 and Mechanical Ventilation

Ventilation and Acceptable Indoor Air Quality in Low-Rise Residential Buildings (ASHRAE Standard 62.2-2003) is part of the Maine Model Building Energy Code, so when following the Code this ventilation standard must be followed also. To comply with ASHRAE 62.2-2003 follow these steps:

1. Determine the whole building ventilation requirement from **Table 5**. Whole building ventilation may be provided with a bathroom or kitchen fan that also provides local ventilation. If this whole building fan is intended to operate continuously, it must operate quietly at one **sones** or less. The control for this ventilation must be automatic (with accommodation for occupant override) or provided by a “fan on” switch that is part of a heating and/or air conditioning system when ductwork is used for introducing fresh air.

This whole building fan should operate when the house is closed up and occupied.

2a. Install a local exhaust fan of 50 CFM (cubic feet per minute) in each bathroom designed for intermittent operation at a sone level of three or less. Control should be provided with an on/off switch on location.

2b. Or, install a 20 CFM exhaust fan in each bathroom that operates continuously at a sone level of one or less. The fan must operate without occupant intervention, but must have an override feature.

3a. Install a local exhaust fan of 100 CFM in the kitchen that runs at a sone level of three or less. Control should be provided with an on/off switch on location.

3b. Or, install a continuously operating kitchen exhaust fan providing five kitchen air changes per hour. The fan must operate without occupant intervention, but must have an override feature.

4. Vent the clothes dryer to the outdoors.

5. Ensure combustion appliances do not backdraft when all exhaust appliances are operating simultaneously and house is closed up.

6. Ensure that the attachment between the house and garage will prevent migration of contaminants.

7. Install openable windows in habitable spaces, toilet, and utility spaces not less than 4 percent of floor area.

Mechanical ventilation can be provided either with exhaust-only fans or with **heat recovery ventilators**, sometimes called **air-to-air heat exchangers**.

Whole Building Ventilation Requirement			
Cubic Feet per Minute (new homes, continuous fan operation)			
Floor Area (ft ²) of Conditioned Space	Number of Bedrooms		
	0 - 1	2 - 3	4 - 5
< 1500	30	45	60
1501 – 3000	45	60	75
For homes larger than 3000 ft ² and homes with more than five bedrooms, see ASHRAE Standard 62.2-2003, Table 4.1a.			

Exhaust-only fans, including kitchen and bathroom fans, are the most common means of providing mechanical ventilation. Makeup air is provided by air infiltrating through cracks around windows, doors, and other leakage areas. One problem with this ventilation strategy for very tight houses is that

there are few leakage sources, so the house ends up operating under negative pressure while the exhaust fans are operating.

While slight negative pressure is not a big problem by itself, it can create hazardous conditions within the house. If there are any non-direct-vent combustion appliances, the negative pressure can cause **backdrafting**—pulling potentially hazardous flue gases into the house instead of allowing them to exit through the chimney. Negative pressure in the house can also pull radon gas into the basement from the ground (see discussion below).

To minimize negative pressure problems in tight houses with exhaust-only ventilation, **air inlet vents**—essentially intentional holes—can be installed in the exterior walls of the house. This may sound contrary to good sense: after making an effort to make the house tight, who would want to put holes in the house? However, the idea has merit as a simple strategy to supply makeup air for exhaust-only ventilation systems. For one thing, you can control where the inlet vents will be and install them in locations where a slight draft will not be noticeable. In addition, you can control the total area of vents precisely and install exactly as many as required to balance the exhaust ventilation system being installed (manufacturers of quality ventilation systems will be able to help you size the inlets).

Another option is **heat recovery ventilation**. Heat recovery ventilators exhaust stale air from the house and, at the same time, bring in an equal amount of fresh outdoor air. In addition, they preheat the incoming fresh air to some extent by transferring thermal energy from the warm exhaust air to the cold, fresh, incoming outdoor air. The house does not experience negative pressure, and the makeup air does not have to be heated as much as it does with the other ventilation strategies. A high-quality heat recovery ventilator will recover 60 to 85 percent of the heat that would otherwise have been lost by exhaust-only mechanical ventilation.

The most significant problem with heat recovery ventilation systems is that both tradespeople and homeowners are often unfamiliar with

the equipment. Heating and air conditioning contractors have little experience with it, and they are reluctant to risk their reputations on an unfamiliar technology.

Perhaps because homeowners cannot see what a heat recovery ventilator is doing and the problems associated with *not* using one are not immediately obvious, homeowners tend to turn them off. Until the heat recovery ventilator industry grows to the point where it can afford a broad educational campaign to convince homeowner of their value, these problems will probably persist.

Radon

Radon is a colorless, odorless, radioactive gas present in bedrock throughout much of the country. High radon levels have been found in many parts of Maine. The gas can seep into a house through the basement and increase the risk of lung cancer among the occupants, particularly if they also are smokers.

In recent years, radon and its adverse health effects have generated considerable public concern and a recommendation by the U.S. Environmental Protection Agency (EPA) that every house be tested for the gas. If levels over 4.0 picoCuries per liter (pCi/l) are found, EPA suggests remedial action to bring the levels down below this level.

Houses can be tested for radon levels quite easily using one of several types of low-cost monitors. Unfortunately, there is no good way to test a building *site* for a potential radon problem; the house must be fully completed before a valid radon test can be done. For this reason, all houses should be designed with radon control and mitigation in mind. Fortunately, many of the methods for controlling radon are the same strategies that are used for building energy-efficient houses. Specialized measures are quite simple and relatively inexpensive.

Designing buildings to avoid radon problems involves a three-part strategy: 1) minimize radon entry pathways; 2) minimize negative pressure in buildings (which will pull air into the house through the basement walls and floor, as discussed above); and 3) incorporate strategies to

facilitate future radon mitigation, if necessary. These strategies are shown in **Figure 8**.

Techniques to minimize radon entry into a new house usually focus on the foundation and basement slab floor. They include installing a polyethylene moisture barrier under the basement floor slab; putting steel mesh, fiber mesh and re-bar (reinforcement bar) into the slab to reduce cracking; installing expansion joint

material where the foundation wall and slab meet; caulking cracks around any penetrations in the foundation floor or walls; removing grade stakes and screed boards as the slab is being finished (otherwise they will eventually rot and leave a channel into the sub-slab gravel); sealing the sump cover; waterproofing the outside of the foundation wall; and providing adequate foundation drainage.

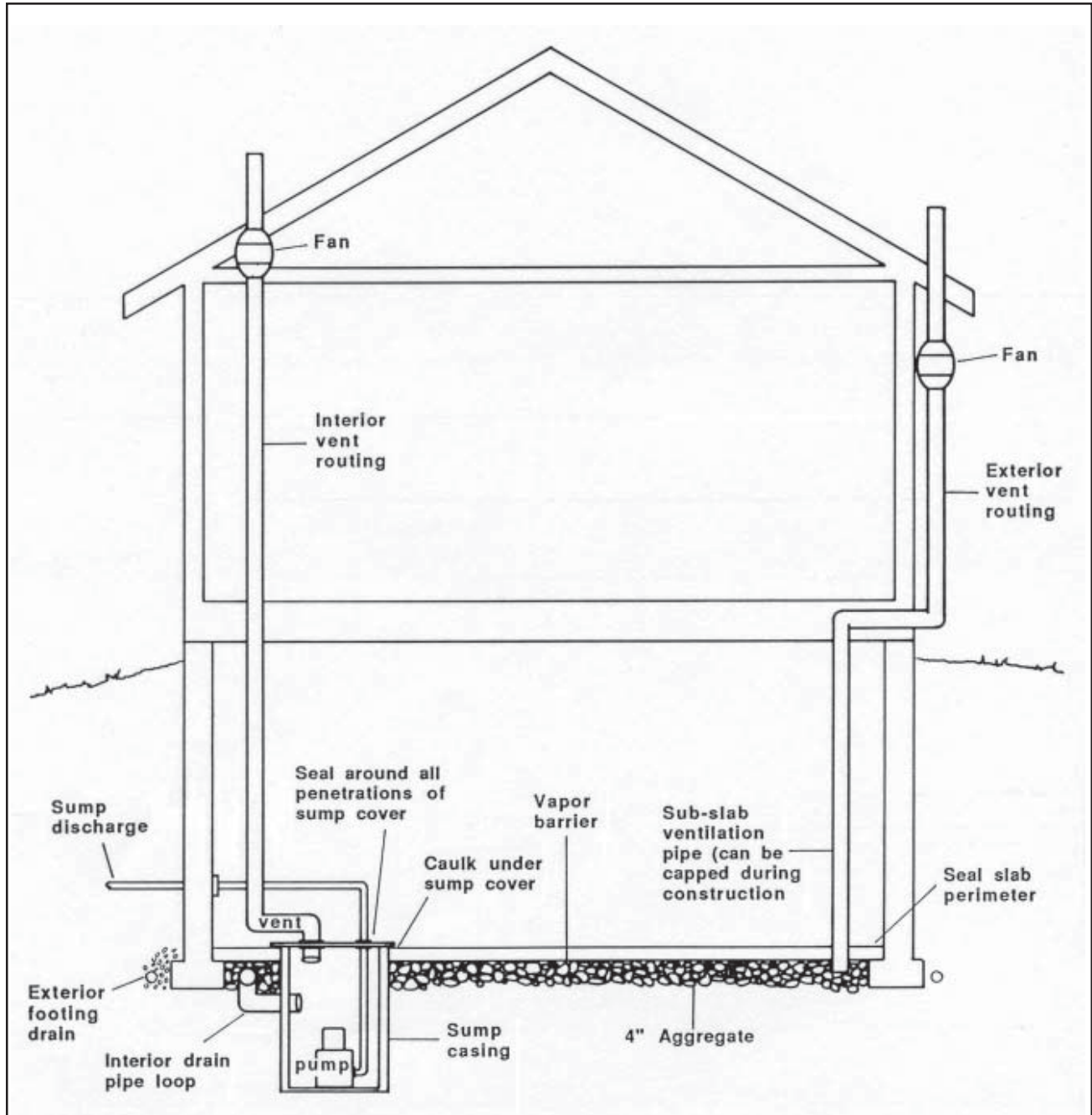

Figure 8. Designing a house to minimize the likelihood of radon problems—and to simplify future radon mitigation if it does become a problem—is quite easy.

To facilitate future radon mitigation—if it ever becomes necessary—the most important strategy is to install four inches of crushed stone or gravel under the basement slab. If high radon levels are ever found, a 4" hole can be drilled into the slab and a plastic pipe inserted into the sub-slab gravel, vented either through the roof or out through a wall. If high radon levels are considered likely, a 4" **standpipe** can be installed before the slab is poured so the radon mitigation system can be activated without having to drill through the concrete floor later. If such a pipe is installed, it is important to label it as a sub-slab radon ventilation pipe so that, in the future, it is not confused with a drainpipe.

Details showing how these techniques can be incorporated into your foundation design are included in the **Recommended Construction Practices** section of this manual (starting on page 39). For more information on radon and indoor air quality issues, including recommended practices for reducing radon problems and a list of approved radon testing and mitigation companies, contact the Maine Radiation Control Program:

*Maine Radiation Control Program
Department of Human Services
Augusta, ME 04333
Phone: 800-232-0842
207-287-5698*

4. Moisture Control

Controlling moisture in buildings involves a two-part strategy: 1) keeping water from entering the house, and 2) effectively keeping water vapor out of insulated cavities. Keeping water from leaking into the house requires the use of standard construction techniques, with particular attention paid to roof flashing, ice dam prevention measures, foundation drainage, and foundation wall waterproofing.

Construction details to prevent leaks are shown in the **Recommended Construction Practices** section of this manual. Follow manufacturers' recommendations for flashing details with skylights, windows and doors. Also, make sure all plumbing is properly installed and protected from possible freezing and rupture, which would introduce water into the house.

Dealing with the second part of the moisture control equation—water vapor—can be more challenging. As a vapor (gas), water does not cause any direct problems. The problem occurs when conditions allow the water vapor to condense into liquid water inside a wall or ceiling cavity, or on an inside surface, such as window glass.

All air contains some water vapor. The amount of water vapor it contains is measured by its humidity. As a mass of air is cooled down, its ability to hold water vapor drops (that's why cold winter air is always drier than warm summer air).

Relative humidity is the amount of water vapor in a sample of air relative to the maximum water vapor carrying-capacity of the air, at a given temperature. If the air mass cools, the actual quantity of water vapor in it remains the same, but the carrying capacity for water vapor is reduced; thus, the relative humidity increases.

As the temperature of the air continues to decrease, it eventually reaches the **dew point** temperature. This is the temperature at which the relative humidity reaches 100 percent. If the temperature drops lower than the dew point, the excess water vapor condenses into a liquid. This liquid water can rot wood and degrade the R-value of insulation.

During the winter, it is much cooler outside the house than inside. If warm air containing water vapor is able to move through the wall cavity toward the outside, it will cool. Depending on the initial relative humidity of the air and the outside temperature, the dew point may be reached inside the wall, ceiling, or floor cavities (see **Figure 9**), allowing condensation to occur, soaking the insulation and potentially rotting framing members. *Air barriers are meant to prevent this potentially damaging air flow from occurring.*

Even if warm inside air cannot readily flow into construction cavities, water vapor is sometimes able to **diffuse** through materials into the wall cavity. The ability of water vapor to diffuse through different materials is measured by the **permeance** of the material. The permeance, or **perm ratings**, of different materials are shown in **Table 6**. In general, materials with perm ratings of 0.1 to 10 are considered **vapor retarders**; vapor

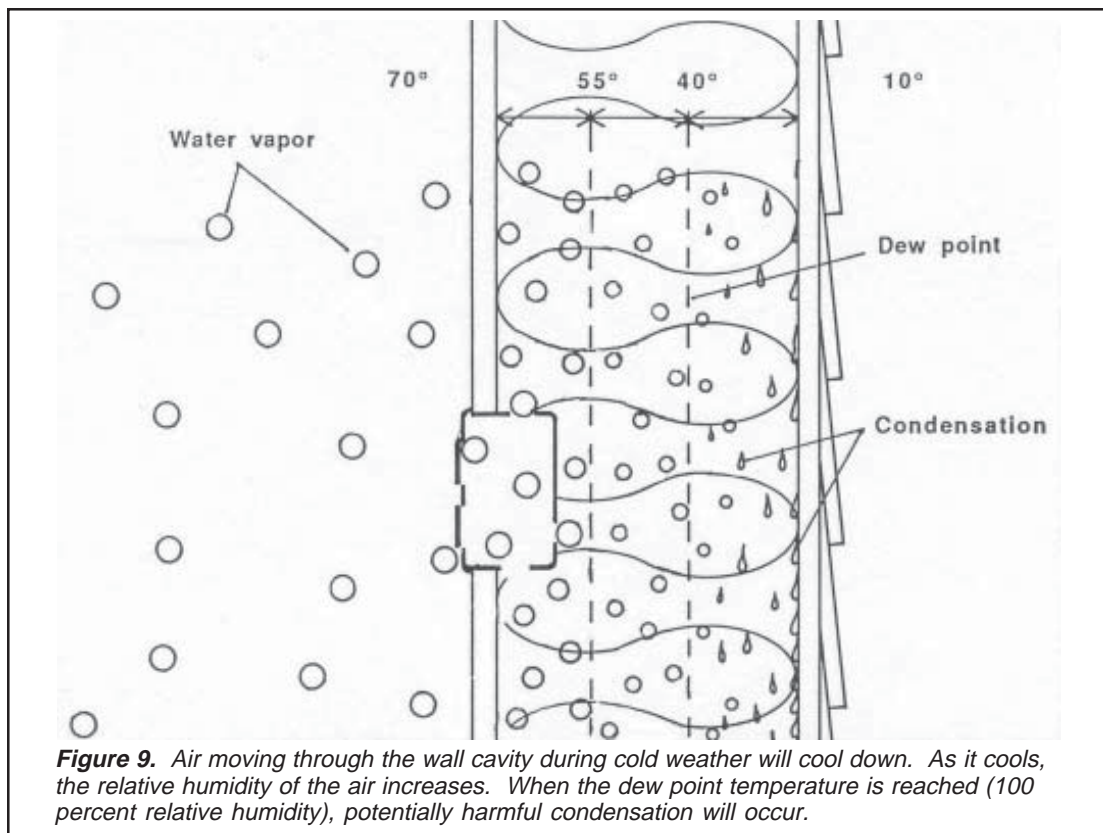

Figure 9. Air moving through the wall cavity during cold weather will cool down. As it cools, the relative humidity of the air increases. When the dew point temperature is reached (100 percent relative humidity), potentially harmful condensation will occur.

barriers are even more resistance to vapor diffusion, having a permeance rating of 0.1 or less.

If conditions are conducive to condensation, as they are in the cold climate of Aroostook county, air and vapor barriers are important to keep insulation dry; prevent possible structural damage from rot, corrosion, or freezing; and to reduce paint failure. Air barriers are equally as important in the other counties of Maine, but vapor retarders are recommended instead of vapor barriers.

To prevent water vapor condensation within wall cavities, there are a number of important rules, some of which apply to the construction of the house and some of which apply to living in the house.

First, follow the practices discussed previously in the air leakage section to keep the building envelope as tight as possible. Studies have found that most of the water vapor that gets into wall cavities is carried by air moving through the wall, rather than as water vapor gradually diffusing through interior building surfaces. Eliminating air leakage is, therefore, an excellent defense against

problems caused by condensing water vapor. The effectiveness of an air barrier can be significantly reduced even if it has small holes in it.

Second, when building a house, install a vapor retarder or barrier on the *warm* side of the wall, ceiling, and floor cavities (toward the living space). The most common vapor barrier is 4- to 6-mil polyethylene, which, if air sealed, can also serve as an air barrier. A good vapor retarder is kraft paper backing on fiberglass insulation.

Third, try to eliminate any obvious *sources* of water vapor. Do not store large quantities of freshly cut firewood in a basement—drying wood releases large quantities of water vapor and uses energy for the evaporation process.

Install exhaust ventilation fans or heat recovery ventilators in areas where large quantities of water vapor are generated (kitchens and bathrooms).

Make sure clothes dryers are vented to the outdoors. Do not use an unvented kerosene heater (in addition to releasing potentially hazardous combustion gases into the house, these also release large quantities of water vapor). And be sure that the foundation is properly protected from leakage (a wet basement floor can add large quantities of

TABLE 6
Perm Ratings of Common Materials

<i>Type</i>	<i>Material</i>	<i>Perm Rating</i>
Masonry	Concrete block (8")	2.4
	Brick masonry (4")	0.8
Exterior Wall Materials	Plywood, exterior	0.7
	Pine, tongue-and-groove	4.5
	Clapboards	8.0
Interior Wall Materials	Gypsum drywall (1/2")	40
	Plywood, interior	1.9
Insulation	Extruded polystyrene (1")	1.2
	Expanded polystyrene (1")	2.0 - 5.8
	Batt insulation, unfaced (1")	116
	fiberglass, cellulose, mineral wool	
Vapor Barriers	Polyethylene (4-mil)	0.08
	Polyethylene (6-mil)	0.06
	Aluminum foil (1-mil)	0.0
	Foil facing on batt insulation	0.5
	Kraft facing on batt insulation	1.0
	Foil facing on rigid insulation	0.0
Paints and Wallpaper	Latex primer sealer	6.3
	"Vapor retarder" paint	0.6
	Primer plus one coat flat oil paint on plaster	1.6 - 3.0
	Enamel paint on smooth plaster	0.5 - 1.5
	Standard wallpaper	20
	Vinyl wallpaper	1.0
Papers and Housewraps	15-lb building felt	5.6
	Air barrier (Tyvek®, Typar®, etc.)	10-40

Source: ASHRAE *Handbook of Fundamentals*, 1997, pp. 24.16-24.17.
Permeance (Perm) = grain/hr, ft², in. Hg

water vapor to the air as the water evaporates).

Fourth, if possible, build wall and ceiling assemblies so that the materials used are progressively more permeable to moisture, moving from the inside toward the outside. If moisture does get into a wall or ceiling, it will have a better chance of escaping if higher permeance materials are installed on the exterior portions of walls and ceilings. For example, if a vapor retarder is installed on the inside (such as kraft paper), the exterior sheathing, etc. should have a sufficient permeance to allow drying.

For this reason, experts recommend that if foil-faced rigid insulation is used on the outside of a wall assembly, it should be at least 2" in thickness. This ensures that the innermost foil facing will remain warm enough to prevent water vapor from condensing on it. If the rigid insulation is thinner, say 1/2" foil-faced insulation, the inner facing will not have as much R-value between it and the cold outdoor air. This inner facing will, therefore, become colder and is more likely to allow condensation to occur, possibly causing damage.

A rule that originated in Canada relates to keeping a vapor barrier warm enough so that

water vapor will not condense on it. The $\frac{1}{3} : \frac{2}{3}$ rule ensures that the vapor barrier will remain warm enough to prevent condensation problems. The $\frac{1}{3} : \frac{2}{3}$ rule states that $\frac{1}{3}$ of the R-value of the total installed insulation should be to the warm side of the vapor barrier and $\frac{2}{3}$ of the R-value must be to the cold side—toward the outdoors.

Fifth, unheated areas and some cavities should be ventilated to the outdoors. Important areas to ventilate include unheated attics and the air space under the roof sheathing in insulated cathedral ceilings. Ventilating these spaces will allow trapped water vapor to escape.

Finally, homeowners should keep relative humidity levels between 30 and 50 percent during the winter months. The higher the relative humidity, the more likely it is that condensation will occur in wall or ceiling cavities—or on cooler interior surfaces such as window glass.

This is also a favorable humidity range for occupant health. At levels above or below this range, some homeowners may suffer respiratory problems resulting from allergies, bacteria or viruses. Use a humidity gauge or digital hydrometer to monitor humidity levels.

Alternative Methods of Wall Construction

As mentioned above, research by building scientists has shown that the movement of air—and its contained water vapor—through cracks, gaps, outlet boxes and other places is the primary way moisture gets into wall and ceiling cavities. This water vapor can condense, causing rot and the degradation of the R-value of insulation. Much more water vapor gets into wall and ceiling cavities through this mechanism than by diffusion through interior surfaces. For this reason, a number of Canadian building scientists developed a construction technique in the early 1980s that places less emphasis on vapor barriers and more emphasis on blocking air movement through walls and ceilings.

In this Airtight Drywall Approach (ADA) to construction, vapor barriers or retarders are still recommended, but they are down played, relative to air barriers. The ADA method employs the interior finished drywall as the air barrier. The drywall is gasketed and sealed at all joints. This includes sealing the drywall to all electrical outlets and switch boxes, placing special gaskets between the back of the drywall and framing members at

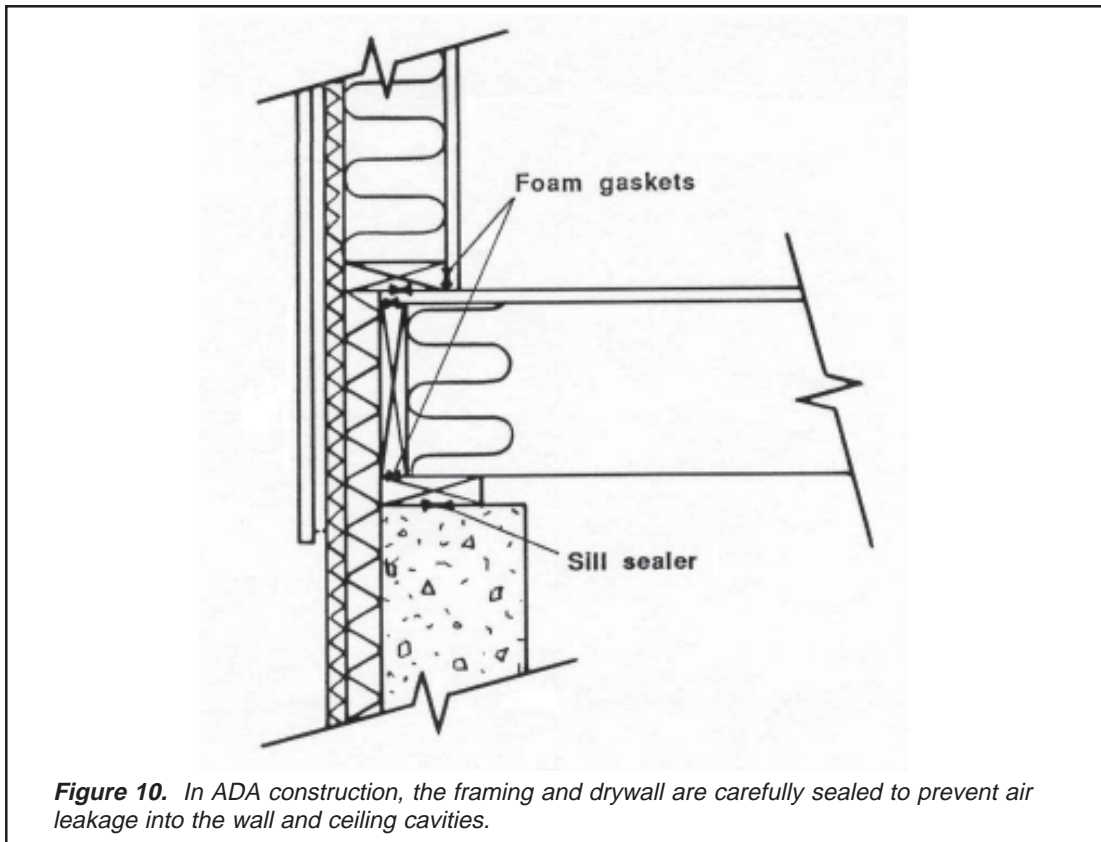

windows, doors, and upper and lower plates. Please refer to **Figure 10** for more details.

The vapor retarder or barrier is then painted on the interior surface of the drywall. This system works well, but requires specialized knowledge to complete.

5. Ventilating Building Cavities

Ventilating roofs and, in some cases, crawl spaces, is also important for controlling moisture and was referred to in the previous section. This type of ventilation is almost always passive; that is, it is done without motors or fans.

Roof Ventilation

Proper roof ventilation will carry away moisture that may accumulate in the insulation. In addition, roof ventilation can play an important role in preventing ice dams. Finally, roof ventilation helps keep roof and attic spaces cooler during warm weather. Almost all roofs should be ventilated, no matter what roof style is used: gable, gambrel, mansard, hip or shed (see exceptions on

page 30).

Proper roof ventilation requires both inlet and outlet vents. The inlet vents should be at the bottom of the roof and the outlet vents at the top so that the natural buoyancy of heated air provides the driving force for the ventilation. Typical ventilation configurations for the most common roof designs are shown in **Figure 11**. Ventilation is most effective when there is a full ridge along the peak of the roof. A continuous soffit vent in the soffits of the eaves provides the inlet, and a continuous ridge vent provides the outlet, as shown in **Figure 12**.

Gable-end vents can be used as the outlet vents in place of ridge vents, or as both inlet and outlet vents. Though not as effective as continuous soffit and ridge vents, a combination of gable-end vents and continuous soffit (inlet) vents is usually satisfactory. Gable-end vents are least effective when used by themselves to provide both inlet and outlet ventilation.

Proper ventilation of mansard and hip roofs is more difficult because there is not a continuous

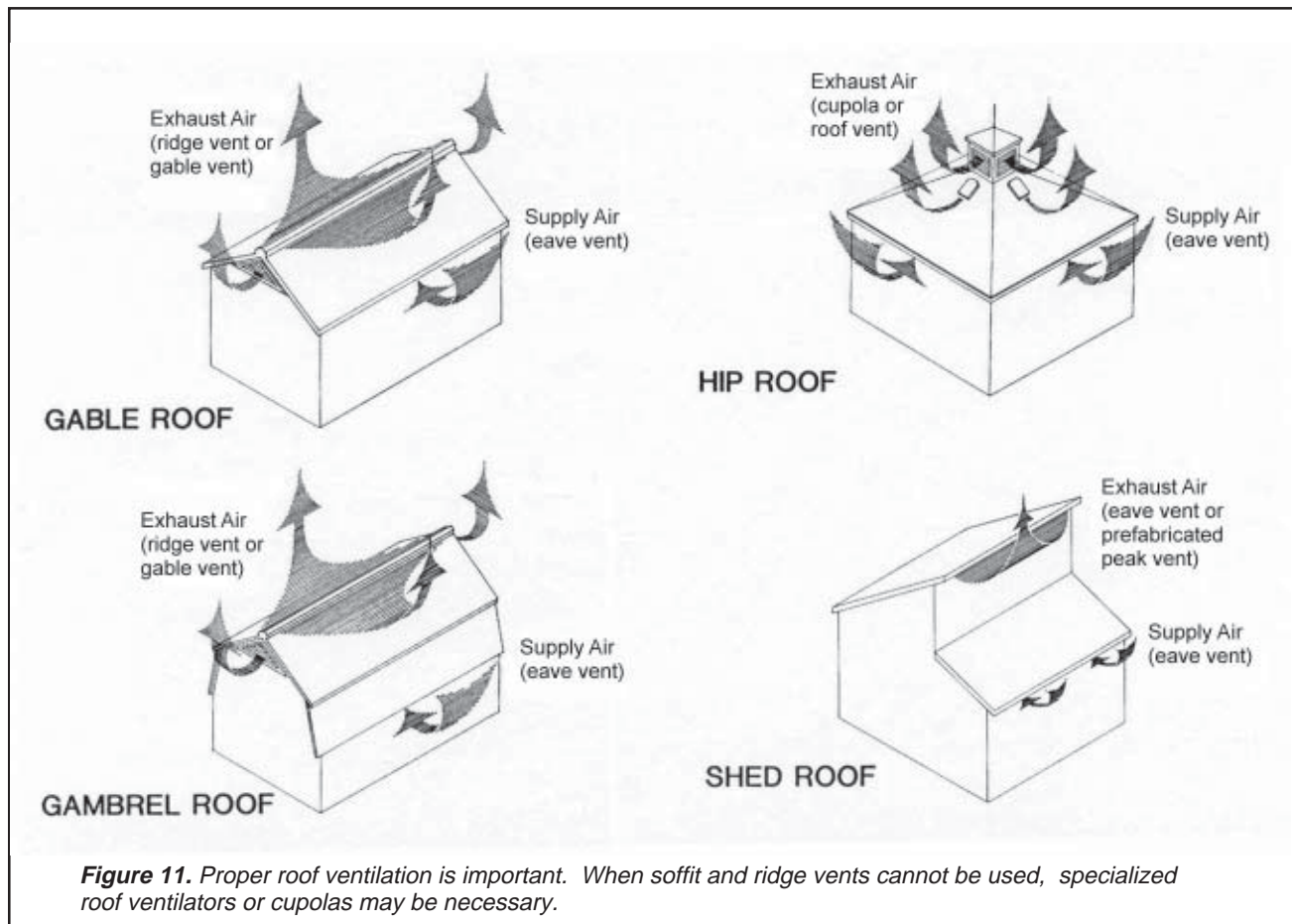

ridge running the full length of the roof. In such cases, cupolas and/or roof ventilators can be used as outlet vents at or near the peak of the roof.

Shed roofs that abut walls are very difficult to ventilate because even specially designed venting products can be readily clogged with snow during the winter. An option for venting these shed roofs is to build vent space within a wall, as shown in **Figure 13**. Warm air rising up the shed roof passes into an air space between the wall sheathing and siding where it can rise to a ridge vent at the peak.

Inlet and outlet vent areas should be the same. A general rule for the area required is one square foot of combined inlet and outlet vent (net free vent area—see below) for every 300 ft² of area to be vented. For example, if ridge and soffit vents are used in combination for a house with a 1000 ft² unheated attic, a total net free vent area of 3-¹/₃ ft² should be provided, one-half of this in the soffit areas and one-half in the ridge. If two gable-end vents are used for this example, one-half of the required free vent area would be installed in each of the two gable ends.

These rules refer to the **net free vent area**, which takes into account the area taken up by louvers and/or screening. If the free vent area is not stamped on the vent you are using, contact the manufacturer for this information. If you are unable to obtain a value for the free vent area of a vent device, assume that 50% of its gross measured area is free vent area.

With insulated cathedral ceilings or the sloped section of ceiling/roof in Cape Cod style houses, vent spacers are required under the roof sheathing to keep the insulation away and provide a continuous channel for airflow. The air space under the roof sheathing should be at least 1" thick to provide adequate air flow.

Providing adequate roof ventilation above and below roof windows and at roof hips and valleys can be quite difficult. Above and below roof windows, one-inch holes can be drilled through the rafters near the top to allow some lateral air flow around the roof window. At hips and valleys, the hip rafters and valley rafters can be dropped down to provide an air space at the top for air flow

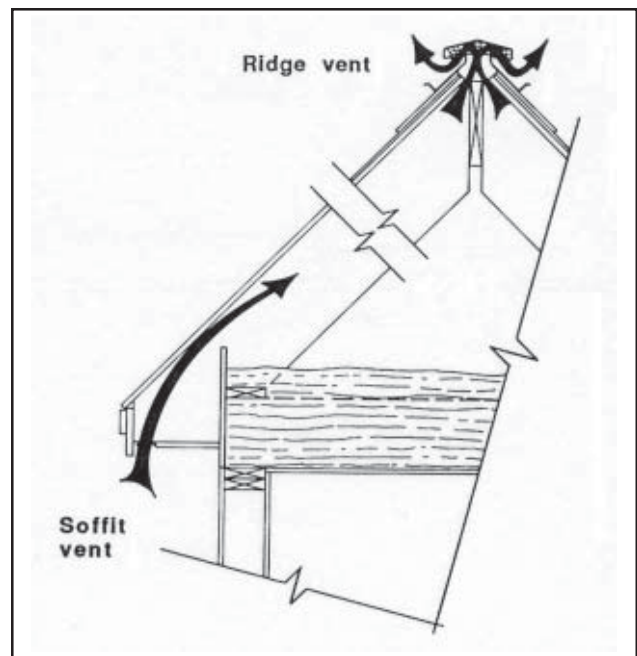

Figure 12. Optimal roof ventilation is provided with continuous soffit and ridge vents — whether for an unheated attic or cathedral ceiling application.

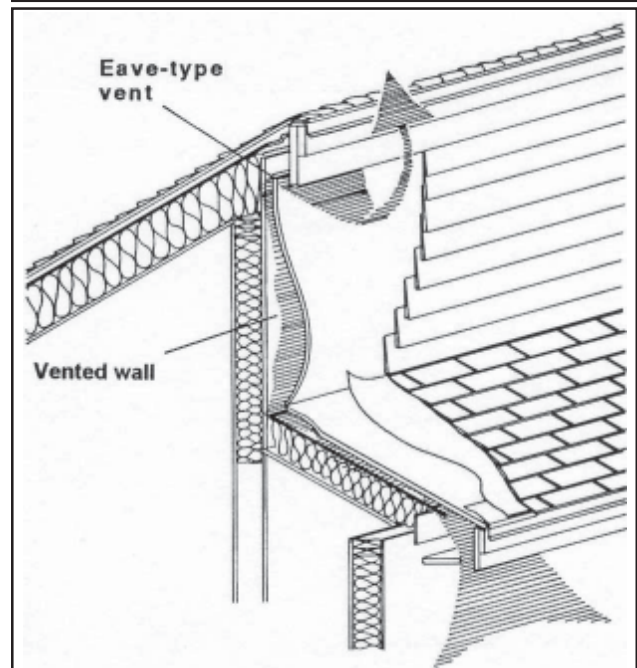

Figure 13. Providing adequate roof ventilation for a shed roof abutting a wall can be difficult. One option is to vent the roof air space into a vented wall.

into adjacent rafter bays where the air can flow up and out the ridge vent. Roof ventilation details, including use of vent spacers, are shown in the **Recommended Construction Practices** section of this manual.

As an exception to this practice of ventilating all sections of roofs, some insulation installers are

now dense packing cellulose insulation into these spaces, leaving no space for ventilation. Apparently this practice works well, allowing a higher insulating value in these sloped ceiling/roof spaces. This should not be done with fiberglass, rock wool, or any other insulation that allows air to flow through it.

Another exception to venting roofs is often referred to as a warm roof. This roof type is insulated with rigid insulation or a structural insulated panel system, or SIPS (rigid insulation laminated to other materials, such as plywood or drywall). The wood roof decking is applied on top of the rigid insulation, then the finish roofing material is installed. No vent space is built into the roof assembly.

Warm roof construction—the use of dense-pack cellulose, Icynene, or any type of rigid insulation—may not be acceptable to local code officers, so talk with the appropriate officials before beginning construction. In addition, there is concern by some that excessive heat buildup may shorten the life of the roof shingles. As a result, you might find that shingle manufacturers will not warranty their shingles on a warm roof; they may insist on roof ventilation that provides for airflow just below the material to which the shingles are fastened.

Crawl Space Ventilation

The need for crawl space ventilation is an area of debate in the building industry today. Some building codes recommend that crawl spaces be vented during the summer months to allow water vapor to escape. If a moisture barrier is used on the ground, one 8" x 16" vent is recommended for each 350 ft² of floor area with a minimum of two vents. Without a moisture barrier, the vent area should be at least doubled. Vents should be screened, open during the summer months, and closed in the winter.

However, there is growing and significant support that crawl spaces and unheated basements *not* be vented during the summer or winter. Experts argue that venting a crawl space during the summer introduces more moisture than it expels. They point out that 1) the incoming air has

a high relative humidity and 2) surfaces in the crawl space or unheated basement are generally cool, causing excessive condensation.

These experts suggest using a full 6-mil polyethylene (or equivalent) ground cover on the crawl space floor with no ventilation. If, for some reason, a full ground cover is not used, the crawl space should be ventilated as suggested above. Refer to the **Recommended Construction Practices** section for details on providing moisture protection and ventilation in crawl spaces. Check with code enforcement officers for requirements.

6. Windows

Windows and glass doors (terrace and patio doors) may account for as much as a third of the heat loss from a typical house. They are the building components with the least resistance to heat loss (the lowest R-value or highest U-factor). As a result, they offer great potential for improving overall energy efficiency.

Until the mid-1980s, the only way to boost the energy efficiency of windows was to add extra layers of glazing or to increase the thickness of the air space between the layers of glazing. In recent years, however, there have been significant advances in window technology, and dramatic increases in window R-values.

The most important development has been the introduction of low-emissivity (low-E) coatings for windows. A thin metal layer is applied to one of the layers of glass or to a plastic film suspended between the layers of glass. This coating allows most of the short wavelength infrared energy from the sun to pass through, but blocks the escape of long wavelength infrared rays emanating from the inside of the house. Low-E coatings add almost as much R-value as an extra layer of glass, while being less expensive and less bulky.

Another major advance has been the use of a gas other than air in the space between the layers of glass in an insulated window. An inert gas between layers of glass is now offered as an option by many major window manufacturers. Different glazing configurations and their resultant R-values are compared in **Table 7**. These are average values; slight differences in air space

thickness, the type of coating and window design may result in somewhat different values. When evaluating windows, read through the manufacturer's literature carefully.

A new method of calculating **R-values** and **U-factors** was introduced by window manufacturers in 1990. The new method takes into account edge losses and, thus, gives a more accurate indication of R-values and U-factors. If you have questions about the insulating value of windows, talk with your dealer or call the State Energy Program.

Along with the glazing configuration, the type of window and its construction also have a big effect on energy efficiency—primarily due to air tightness. Casement windows, for example, are typically tighter than double-hung windows. Windows and doors are tested for air tightness by manufacturers under carefully controlled conditions. The measured air tightness, in cubic feet of air per linear foot of crack (cfm/ft), should be listed in the manufacturer's literature. Of the most common window types, casements and awnings are generally the tightest, followed by sliders and double-hung windows, but you will find considerable variation from manufacturer to manufacturer, depending on the weatherstripping and closure details used. There may also be differences in air tightness with different frame materials: wood,

vinyl-clad wood and metal. The air leakage values of different window models offered by one particular manufacturer are listed in **Table 8**.

When choosing windows, be sure to study energy efficiency carefully. Compare different brands and also the different styles offered by the same manufacturer.

It is usually best to purchase pre-manufactured windows rather than trying to fabricate your own. Fixed windows are generally the tightest, followed by casement (including awning, hopper, and skylights) and then double hung. It is always best to avoid low quality windows.

Another way to increase the insulating value of windows is to install and use movable **window insulation**, either soft insulated shades or rigid insulated shutters. These insulating devices also often serve as cosmetic window coverings, a feature that most home occupants welcome. The material should include a vapor barrier membrane close to its inside surface. These tight-fitting interior shades or shutters are drawn over the window glass on cloudy winter days and during the night. In addition, they can be drawn to control solar gain through window glass.

The R-values of these materials can be significant—as much as an additional R-4 above the

TABLE 7
Glazing Configurations and R-Values

<u>Glazing Configuration</u>	<u>R-Value</u>	<u>U-Factor</u>
Single glazing	0.87	1.15
Double glazing, 3/16" air space	1.7	0.59
Double glazing, 1/2" air space	2.0	0.5
Triple glazing, 1/2" total air space	2.3	0.43
Triple glazing, 1" total air space	2.6	0.38
Double glazing, vinyl frame, low-E	2.78	0.36
Double glazing, vinyl frame, argon filled, low-E	3.0	0.33
Triple glazing, vinyl frame, argon filled, low-E	3.45	0.29
Triple glazing, vinyl frame, krypton filled, low-E	4.76	0.21

TABLE 8
Air Leakage Values for Different Windows
from One Manufacturer

<i>Window Type</i>	<i>Air Leakage (cfm/ft)</i>
Casement	.03
Awning	.07
Double-hung	.17
Slider	.13
European-style combination side and bottom hinged	.01
Roof window	.03
Sliding patio door	.17
Hinged terrace door	.07
Hinged French doors	.10

window itself. Of course, the increased R-value is only effective if the window insulation is drawn in place over the window glass.

The Maine Model Building Energy Code does not recognize window insulation as a method of complying with the required R-value of windows—the insulating value of the windows themselves must comply. However, movable window insulation can be a cost-effective way of reducing heat loss or unwanted solar gain through the window and door glass.

7. Doors

Like windows, exterior doors can be big energy wasters, both due to heat loss through the doors, and air leakage around poorly sealed units. The biggest decision in buying a door, from an energy use perspective, is whether to buy a solid wood door or an insulated door. Solid wood doors are generally preferred from an aesthetic standpoint, but they provide less resistance to heat flow. A 2" thick solid wood door insulates to about R-2.2. With a wood storm door, the total R-value can be boosted to about 3.5. An insulated metal or fiberglass door, by contrast, can provide between R-2.2 and R-6, without a storm door. Furthermore, metal and fiberglass doors generally seal

more tightly and are less likely to warp with weather exposure. Warping can greatly reduce the air tightness in wood doors. Metal doors with magnetic weatherstripping are generally the tightest because of the refrigerator-like seal between the door and jamb.

If an air-lock entry is used, the energy penalty for installing a wood door will be reduced, but the energy performance will still be lower than with an insulated metal door. No matter which type of door you decide on, be sure to buy only pre-hung units. Factory-installed weatherstripping is far better than what you can provide with site-hung doors, and the tolerances will generally be much tighter.

8. Heating Considerations

How successful you are in building a tight, energy-efficient house is measured by its heating requirements and by the comfort of the occupants. Refer to **Appendix A** for information on calculating the heat load of a house and installing an appropriately sized heating system.

Successfully keeping heating bills down depends on three important factors: 1) the energy-efficiency of the house; 2) the heating system used—its efficiency and fuel type; and 3) the

occupants' behavior, which is beyond the scope of this manual. You can maximize your investment in an energy-efficient house by heating it with a high-efficiency heating system.

New oil-fired furnaces and boilers deliver heat at a minimum seasonal efficiency of 80 percent. New gas-fired heating systems are at least 78 percent efficient, with condensing gas furnaces operating at efficiencies as high as 95 percent.

The extra cost of buying a higher efficiency boiler or furnace rather than one that is the minimum efficiency will usually payback in just five to seven years in a house built to Maine Model Building Energy Code.

A thorough discussion of available high-efficiency heating systems is beyond the scope of this manual, but several important points should be made.

Electric resistance heating is generally the cheapest type of heating system you can *install* (from an initial cost standpoint), but the most expensive to *operate*. Given electricity prices in most areas of Maine, electric resistance heat should be avoided in almost all cases. Air-source heat pumps, which deliver more heat per unit of energy consumed, have proven to be a *questionable* heating choice for Maine because their performance drops dramatically in cold weather (below about 30°F). However, water-source heat pumps using geothermal energy from water wells or ground loop piping systems often have proven to be cost effective when both heating and cooling are required.

With oil-fired furnaces and boilers (furnaces heat and distribute air, while boilers heat and distribute water), efficiencies over 80 percent can be achieved with high-speed flame-retention burners.

For gas-fired furnaces and boilers, look for **condensing systems** with efficiencies over 90 percent.

As mentioned in the **Indoor Air Quality** section of this manual (page 19), direct-vent combustion furnaces and boilers minimize the risk of backdrafting hazardous combustion gases into the house. These systems draw combustion air from outdoors through a dedicated pipe and

exhaust flue gases directly to the outdoors, without any interaction with the air in the house. Today many housing experts strongly recommend direct-vent combustion appliances over conventionally vented appliances for new energy-efficient homes.

In planning the heating system, pay particular attention to the controls. Setback thermostats can reduce heating bills dramatically: Up to a point, each 1°F night setback can save up to 1 percent on yearly heating bills.

If there are portions of the house that will be used little or that have different heating requirements, put them on separate **zones** controlled by their own thermostats.

For some hot water heating systems, it may make sense to consider specialized **reset controls** or modulating aquastats, which regulate boiler temperatures according to outside temperatures. Instead of always circulating 180° water through baseboard radiators, a reset control lowers the water temperature when heating demands are lower—this reduces heat losses from the boiler and saves fuel.

Many homeowners building new houses want a fireplace or wood stove, sometimes for aesthetic reasons rather than for saving energy. Wood stoves are far more energy-efficient than fireplaces, and should be recommended over fireplaces whenever possible. In fact, conventional fireplaces—without combustion air supplies, tight-fitting dampers and glass doors—usually waste more heat than they provide. Even though a fireplace may warm the area immediately around it, using the fireplace may actually make the heating system work harder, because the fireplace pulls large volumes of air out of the house. This lost air is replaced through infiltration of cold outside air, which must be heated.

In a tight house, it may be necessary to open a window to provide adequate draft if there is not adequate combustion supply air for the fireplace. Refer to the **Air Leakage** section for measures that can be taken to make fireplaces more efficient.

Most wood stoves on the market are fairly energy-efficient. The highest efficiency wood stoves have catalytic combustors or secondary air supplies to help burn flue gases before they go up

the chimney, which both cuts down on pollution and boosts efficiency.

Equipment Installation and Maintenance

Proper sizing, installation, and maintenance of heating and cooling equipment are major factors in operating efficiency. In fact, the potential energy savings from a high-quality installation are greater than those gained from the installation of high-efficiency equipment.

Improper sizing and inferior installation can increase heating costs as much as 16 percent and cooling costs by as much as 35 percent over properly sized and installed equipment. Moreover, proper installation and maintenance practices can provide substantial non-energy benefits, such as greater comfort, lower maintenance costs, and longer equipment life.

When installing furnaces and boilers, be aware of the temperature rise across the heat exchanger, blower thermostat control, fan-relay delay, thermostat anticipator, programmable thermostat specifications, and system sizing.

For air conditioning, check the indoor coil airflow, refrigerant charge, refrigerant lines, programmable thermostat specifications and system sizing.

When ductwork is installed, be conscious of the duct sizing and layout, register and grille locations, balancing dampers, duct sealing materials, and final duct leakage tests.

Sizing Heating Systems

Heating systems are often oversized. This mistake is probably more likely to happen in energy-efficient houses. Heating contractors are accustomed to installing 100,000 to 150,000 Btu/hr. furnaces or boilers, and they have trouble accepting the idea that a new house may only require 20,000 to 50,000 Btu/hr. If an oversized system is installed, it will operate inefficiently because it will be cycling on and off. Frequent on-and-off cycling is inefficient and reduces the life of the heating plant. For the highest efficiency and greatest comfort, a heating system should be oversized by no more than 20 percent. However, if you are using a boiler for domestic hot water as well, you may need more capacity.

To size a heating system, you or your heating contractor need to know what the expected maximum heating load for the building will be. On a cold day, how many Btus per hour will it take to keep the house comfortable? An architect or heating contractor should be able to tell you the **heating outdoor design temperature** for your area. In Maine, outdoor design temperatures range from 0 to -15°F (these are 97-1/2 percent outdoor design temperatures, meaning that 97-1/2 percent of the time, during the three coldest months of the year, temperatures will not drop lower). Heat loss and heating load calculations are discussed in **Appendix A**.

9. Energy-Efficient Appliances

As we build more energy-efficient houses, the *percentage* share of the total energy bill due to water heating, electrical appliances and lighting increases. In very efficient (non-electrically heated) homes, it is not unusual for electricity bills to exceed heating bills. Fortunately, there is significant opportunity to keep electric costs down by choosing high-efficiency water heaters, appliances and lighting.

Typical annual operating costs for home appliances are shown in **Table 9**. It shows both the costs for average existing appliances and efficient new appliances.

In some cases, significant savings can be realized by switching from electricity to gas; this may be the case with water heaters and dryers. While the savings will be greatest with natural gas, higher cost liquefied propane (LP) gas will usually also save money over electricity.

For gas or electric ranges, a range hood vented to the outside should be operated while a range burner or the oven is in use. This will facilitate the venting of combustion and cooking by-products to the outdoors, making the indoor air healthier.

Gas water heaters should be either the direct vent type or mechanically vented for indoor air quality reasons. These units can be slightly more efficient than conventional types, but more importantly, they are safer to operate in a tight, energy-efficient house.

TABLE 9
Typical Appliance Operating Costs (Annual)

<u>Appliance</u>	<u>Average Existing Appliance(s)</u>	<u>Very Energy-Efficient New Appliance(s)</u>
Water heater (electric)	\$840	\$490
Water heater (natural gas)	690	420
Refrigerator (manual defrost)	150	53
Refrigerator/freezer (frost-free)	200	60
Freezer (manual defrost)	130	50
Freezer (frost-free)	150	70
Air conditioner (central)	420	200
Air conditioner (1 room)	50	30
Electric range	100	94
Clothes washer (w/ elec. water heating)	200	*40
Dishwasher (w/ elec. water heating)	130	40
Color television	70	50
Household lighting	140	**50

* Assumes washing clothes in cold water.

** Compact fluorescent lighting.

Note: Operating costs assume electricity at .14¢/kWh, gas at \$1.80/therm.

Source: *Consumer Guide to Home Energy Savings*, 8th ed., American Council for an Energy-Efficient Economy, Washington, D.C., 2003.

With water heating, you should also consider an **indirect-fired water heater** that operates off an oil- or gas-fired boiler or furnace. This is a very efficient type of water heater and should not be confused with the older **tankless coil** water heater, which wastes energy during the summer months when the heating system is not being used. An indirect-fired water heater allows the boiler or furnace to operate for short spurts, during which time the water in a separate tank is heated via a separate heat exchanger.

Carefully study the **Energy Guide labels** when shopping for new appliances. Energy Guide labels are required on all new refrigerators, freezers, water heaters, clothes washers, clothes dryers,

dishwashers and room air conditioners. These labels display the yearly average energy cost to operate the appliance and provide a comparison with the energy costs of similarly sized models. If you are a builder, discuss appliances with your clients and, where features and style suffice, help them select those that are the most energy efficient.

Using appliances with ENERGY STAR ratings reduces operating costs and increases a home's value for the homeowner. ENERGY STAR is a Federal EPA program that rates products and buildings that exceed the basic federal energy-efficiency standards. For example, an ENERGY STAR-rated refrigerator must use 10 percent less energy than one that just meets the Federal mini-

mum standard.

The ENERGY STAR label is now available for furnaces, boilers, central and room air conditioners, heat pumps, programmable thermostats, refrigerators, dishwashers, clothes washers, televisions and related electronic equipment, lighting products, computers and computer monitors, and a variety of other office equipment.

In addition, a home can be ENERGY STAR-certified by an approved energy auditor. An ENERGY STAR home might qualify for preferential financing, its operating costs will be minimal, and its resale value will be higher. The ENERGY STAR level of energy efficiency approximately equates to that of the Maine Model Building Energy Code.

10. Energy-Efficient Lighting

In the past ten years, there have been many technological changes in area of lighting, opening the door to dramatic energy savings. With tubular fluorescent lights, we have seen the introduction of quiet, flicker-free electronic ballasts and improved-color lamps that make this type of lighting much more acceptable in the residential environment.

An even more exciting development was the introduction of **compact fluorescent lamps**. The light quality from compact fluorescent lamps is similar to that from incandescent lamps, yet they consume about one-third to one-quarter as much electricity for a given amount of light, *and* they last as much as ten times as long. There are two basic types of compact fluorescent lamps: lamp-only units that plug into suitable ballasts, and units with integral ballasts that can simply be screwed into standard light bulb sockets.

In new construction, when deciding on which fixtures to install, it makes sense to buy fixtures specially made for the plug-in compact fluorescent lamps. These fixtures have built-in ballasts; if the lamp fails, it can be inexpensively replaced. With fixtures designed for standard incandescent light bulbs, make sure that compact fluorescent lamps (with integral ballasts) will fit.

For outdoor lighting, there are now compact fluorescent lamps, high-pressure sodium, metal halide lamps, all of which are more energy-efficient than outdoor incandescent lamps. Make

sure the lamps you use are rated for outdoor use. Always compare the lumen output and Watt input when deciding which lamp type to purchase and use.

You might also want to look carefully at your outdoor lighting requirements. Outdoor spaces around houses are often over-lit, and savings might be achieved by using fewer or lower-wattage lamps.

In addition, there have been advances in the area of lighting controls. There are sound- and motion-activated controls, programmable controls that can be operated from a remote location by telephone, and controls that adjust lighting intensity relative to daylight levels. While most of the interest in energy-efficient lighting has so far been limited to commercial and industrial buildings, interest is growing among homeowners now that lamp prices are falling and energy prices are increasing.

11. Promising Technologies

There are a number of technologies that hold promise for the future. Some of these technologies might alter energy use significantly, others might alter it only slightly, while giving home owners more choices. The next generation will know the outcomes.

Fuel Cells

Fuels cells generate electrical energy using an electrochemical process that converts hydrogen and oxygen directly into electrical energy without combustion. These devices have no moving parts and operate somewhat like your car battery, but operate continuously – without recharging – as long as fuel is supplied.

There are a number of advantages to this technology. Fuel cells are the most efficient method for producing electricity: they maintain high levels of efficiency over a broad operating range, they have no moving parts, they are quiet, and they are the most environmentally friendly of electric generation technologies (they discharge only water vapor and carbon dioxide).

Of the four fuel cell technologies that show economic promise, the solid polymer fuel cell, more commonly known as the PEM or Proton

Exchange Membrane, has the greatest likelihood of use in the residential market. These cells are now available in a variety of sizes, including some for very small-scale applications (less than 100 watts). It is likely that, within the next five years, PEM fuel cells will be widely available for supplying electrical and heating needs in homes.

A prototype project installed in the late summer of 2002 is providing up to 5kW of electricity to a model home in Colorado, while the heat generated by the fuel cells is used for domestic hot water and space heating.

For more information about fuel cell technology, go to www.eere.energy.gov/RE/hydrogen_fuel_cells.html.

Photovoltaics

Photovoltaic, or PV, systems convert light energy into electrical energy. Many useful devices use this technology, including calculators, wrist watches, traffic signs, railroad signals, battery chargers, and water pumps in remote areas. In a surprising number of cases, PV power is the least expensive way of performing these tasks.

PV systems have several advantages: they are cost-effective alternatives in areas where extending a utility power line is very expensive, they have no moving parts, they are inexpensive to maintain, and they do not pollute the environment.

PV systems are commercially available as stand-alone systems, with battery storage, with

backup generator power, with a connection to the local electric utility grid, or as combinations of these options.

A possible system in Maine might include PV panels on the south-facing roof, with battery storage and a generator. During sunny days, the PV modules quietly supply daytime energy needs and charge the batteries. If the batteries run low, the combustion-powered electric generator runs at full power—it's most efficient level of operation—until the batteries are recharged.

For more information about PV technology, design, and use go to www.eere.energy.gov/RE/solar_photovoltaics.html.

Hybrid Systems

There are many hybrid residential power systems throughout the state using PV, wind, and even micro-hydro. During sunny or windy days and on days with sufficient water flow, these hybrid systems provide daytime energy needs and charge banks of batteries. A typical system usually incorporates a backup generator for electricity on-demand when it is not available from the batteries. As the cost of conventional fuels increases and the cost of renewable energy equipment falls, hybrid systems are likely to become more popular.

Advances in Heat Pumps

There are two basic types of heat pumps: those that use the outdoor air as a source and a dump for heat (air-source) and those that use water as a source and dump for heat (ground-source).

Air-source units have not been economical in the cold climate of Maine because their heating efficiency drops as the outdoor temperature drops. Ground-source units have higher efficiencies because the ground water temperature is less variable than the air temperature, but they cost significantly more than air-source units. As a result of these technical and cost issues, heat pumps have never become a significant space conditioning option for residential buildings in Maine. However, this might be changing.

<i>Appliance</i>	<i>Energy Star Efficiency Level</i>
Clothes washers	50%*
Dishwashers	25%*
Refrigerators	10%*
Room air conditioners	10%*
Air-source heat pumps	15-20%* (7.6 HSPF/12 SEE)
Geothermal heat pumps	2.8 COP/13 EER
Boilers	6%* (85% AFUE)
Furnaces	15%* (90% AFUE)
*Indicates percentage more efficient than the minimum Federal energy standard as of September 2002.	

The cold climate heat pump is an air-source unit that claims an efficiency level as much as two times higher than conventional air-source heat pumps, or as much as 250 percent efficiency. In addition, the makers of this innovative product claim a 25 percent reduction in cooling costs. A number of innovative features are responsible for these increased efficiencies.

Geothermal ground-source heat pump heating systems have been in use in the Bangor area, in both residential and commercial applications, since the early 1970's. These ground-source heat pumps generally have lower operating costs than fossil fuel systems and the benefit of zero local pollution. As the residential and commercial use of this efficient heating/cooling option increases, its biggest obstacle to use—its installation cost—continues to fall.

In the future, it is expected that a combination of ground-source heat pump systems and fuel cells will provide a marriage of technologies for low-cost heating and cooling systems. They also have the advantage, potentially beneficial to rural Maine, of providing a stand-alone energy source, disconnected from the electricity grid.

12. Advantages of Building an Energy-Efficient Home

There are a number of advantages to building an energy-efficient home in Maine, even if your town has not adopted the Maine Model Building Energy Code. An energy-efficient home is more comfortable, has lower energy costs, can qualify for preferential financing, has a higher resale value, and is more environmentally friendly.

The higher levels of insulation result in warmer interior surfaces and a more consistent temperature throughout the house. These features result in a noticeable increase in the comfort for the occupants.

Of course, the greater the level of energy-efficiency, the lower the monthly energy bills. This is a well known benefit of building an energy-efficient house with a low heating bill and efficient appliances.

Although energy-efficient homes generally cost more to build than less efficient ones, the

monthly increase in mortgage costs are more than offset by the decrease in the monthly energy costs. Many financial institutions recognize this benefit to cash flow with their Energy-Efficient Mortgages (EEMs). Qualifying home buyers might benefit from a lower interest rate, greater borrowing power, or fewer points at closing when using an EEM.

Moreover, several reliable studies have shown that the resale value of a house increases by \$20.00 for every \$1.00 reduction in annual energy costs. This benefit can add up to thousands of dollars when an energy-efficient house is sold.

Finally, energy-efficient homes use less energy, making them friendlier to the local and global environment. This benefits all of us.

Part 4. Recommended Construction Practices

The illustrations shown on the following pages provide examples of construction details you may use to satisfy the Maine Model Building Energy Code. These details are not meant to be portrayed as the only options available to you. If you have any questions on these details, or on specific details you are using or plan to use, contact the State Energy Program.

not insulated to levels commensurate with the rest of the building, they can account for as much as 20 percent of the building's total heat loss. That is easy to understand when you consider that an 8-inch concrete wall insulates just slightly better than a single pane of glass. By following the Maine Model Building Energy Code, heat loss attributable to foundations drops to just 5-10 percent. Today's energy prices easily justify the money spent to insulate foundations properly.

1. Foundations

Foundations are often an overlooked area of energy-efficient construction. If foundations are

There are three basic types of foundations

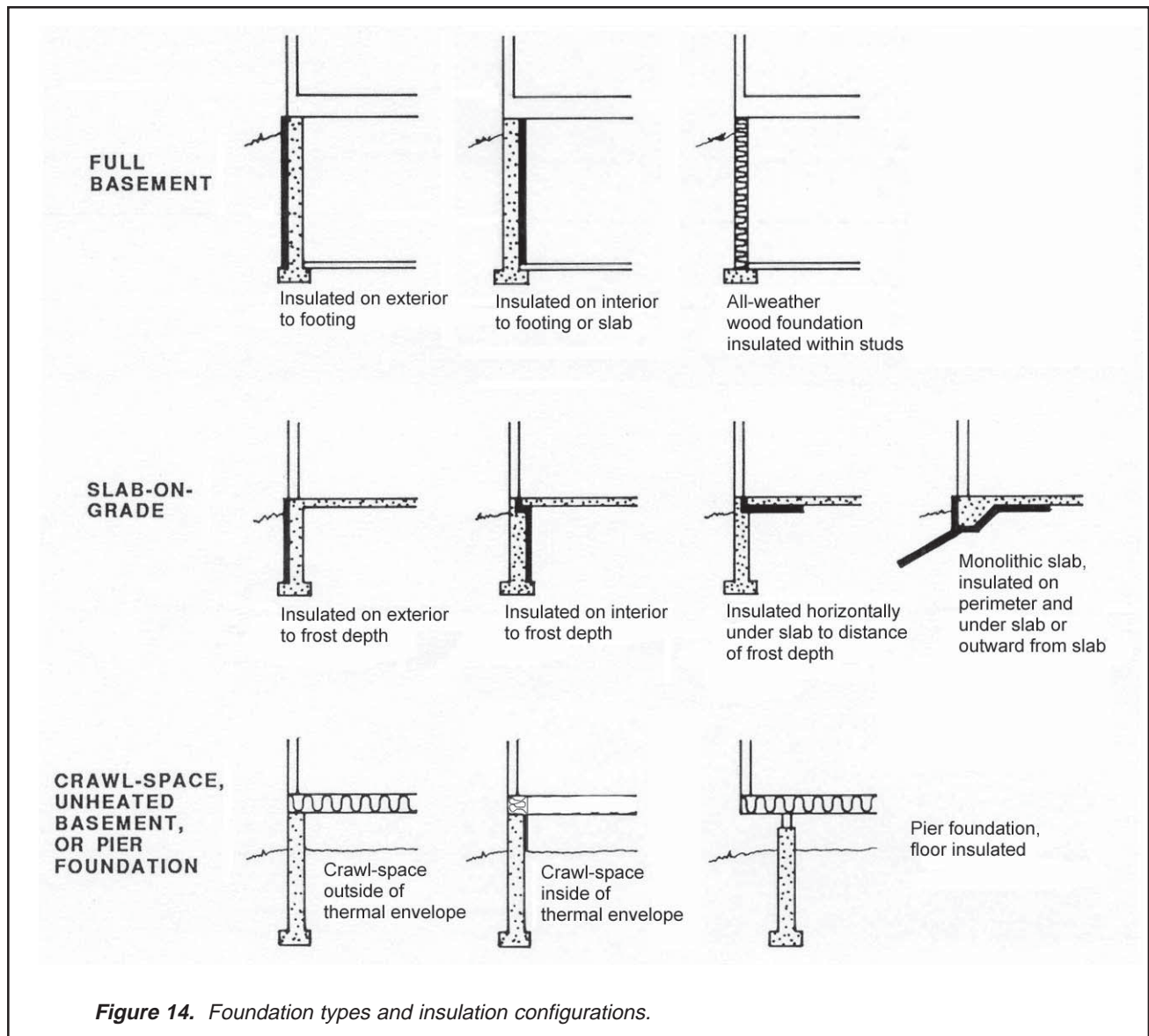

commonly found in Maine, all of which can be effectively insulated. These foundation types and the general prescriptive insulation strategies available for each are shown in **Figure 14**. As shown in **Table 1** (page 2), foundation walls enclosing heated spaces must be insulated to at least R-10 (R-value for the insulation only), and the insulation must extend down to the footing.

With slab-on-grade foundations, R-10 insulation must be used in one of two configurations: 1) either around the full perimeter extending down to the design frost depth, or 2) around the full perimeter of the slab itself, and horizontally or diagonally beneath or away from the slab for a distance equivalent to the design frost depth.

In the case of unconditioned basements or crawl spaces, the floor above the unheated space must be insulated to R-21.

When foundation insulation will be in contact with the ground (on the outside of the foundation wall or under the slab), extruded polystyrene is recommended. It is resistant to moisture and has adequate compressive strength. Under the slab, specify higher density extruded polystyrene if several densities are available. Rigid fiberglass can also be used for below-grade applications, though the R-value and compressive strength are somewhat lower. To achieve R-10 with rigid fiberglass, you will need more than 2" of thickness, probably 2-1/2", but check the rated per-inch R-value of the insulation.

Protection from moisture is a very important consideration for full foundation walls, especially when the basement is to be used as living space. Leaks and drainage problems are very common, particularly when the surrounding soil drains poorly. You should always follow recommended practices for preventing leaks and other moisture problems.

On the outside of the foundation wall, a layer of waterproof or water resistant foundation coating should be sprayed or trowelled on. Break off all foundation form ties and fill any voids before applying the foundation coating to ensure good protection.

To help ensure that leaks do not occur in the damp proofing layer or other areas, water should be able to drain away from the wall. At the surface, slope the ground away from the wall at a minimum slope of 5 percent (6" in 10'). Against the wall, crushed stone, gravel or sand will allow water to flow down to the footing drain rather than build up pressure against the wall surface.

To improve drainage, a specialized **drainage mat** may be installed between the foundation and backfill (outside the insulation if the foundation is insulated on the exterior). This drainage mat intercepts any groundwater or runoff flowing toward the foundation and allows it to quickly drain down to the footing drains and be carried away. Moisture never comes in direct contact with the foundation insulation or foundation wall, so leaks are very unlikely. A number of different foundation drainage products are available, including a loose woven wire mesh with filter fabric, and a corrugated plastic with filter fabric.

Exterior Foundation Insulation

Insulating a concrete foundation on the *exterior* rather than the interior has a number of advantages. It allows the **thermal mass** of the concrete to be used in storing heat, which can be important if passive solar heating has been designed into the house.

Exterior foundation insulation also helps protect the foundation wall from the effects of thermal shock. With the insulation on the exterior, the foundation is not exposed to as great a temperature range over the seasons. This also allows the basement wall to dry to the interior if required.

When insulating a basement foundation wall on the exterior, use at least two inches of extruded polystyrene insulation from the top of the foundation down to the top of the footing after applying a damp proofing to the foundation. Because the foundation wall is likely to get wet at some time during its life, do not install a vapor barrier on the interior of the wall. This allows the wall to dry to the interior if it does get wet.

Several different exterior foundation insulation options are shown in the following illustrations. In **Figure 15**, a 2" layer of extruded polystyrene is installed on the outside of the foundation wall, extending all the way down to the top of the footing. Apply the waterproofing layer first, then glue the rigid insulation on with the appropriate adhesive (refer to the insulation manufacturer's recommendations) or suitable concrete nails and large plastic washers. On the

outside of the insulation, you can install a drainage mat, as described above.

The foundation insulation must be protected from sunlight and abrasion where it extends above grade. Use a stucco coating, pressure-treated plywood or a specialized hardboard covering made for protecting foundation insulation. This protective coating should extend below grade by six inches. When using stucco coatings, use a high quality material designed

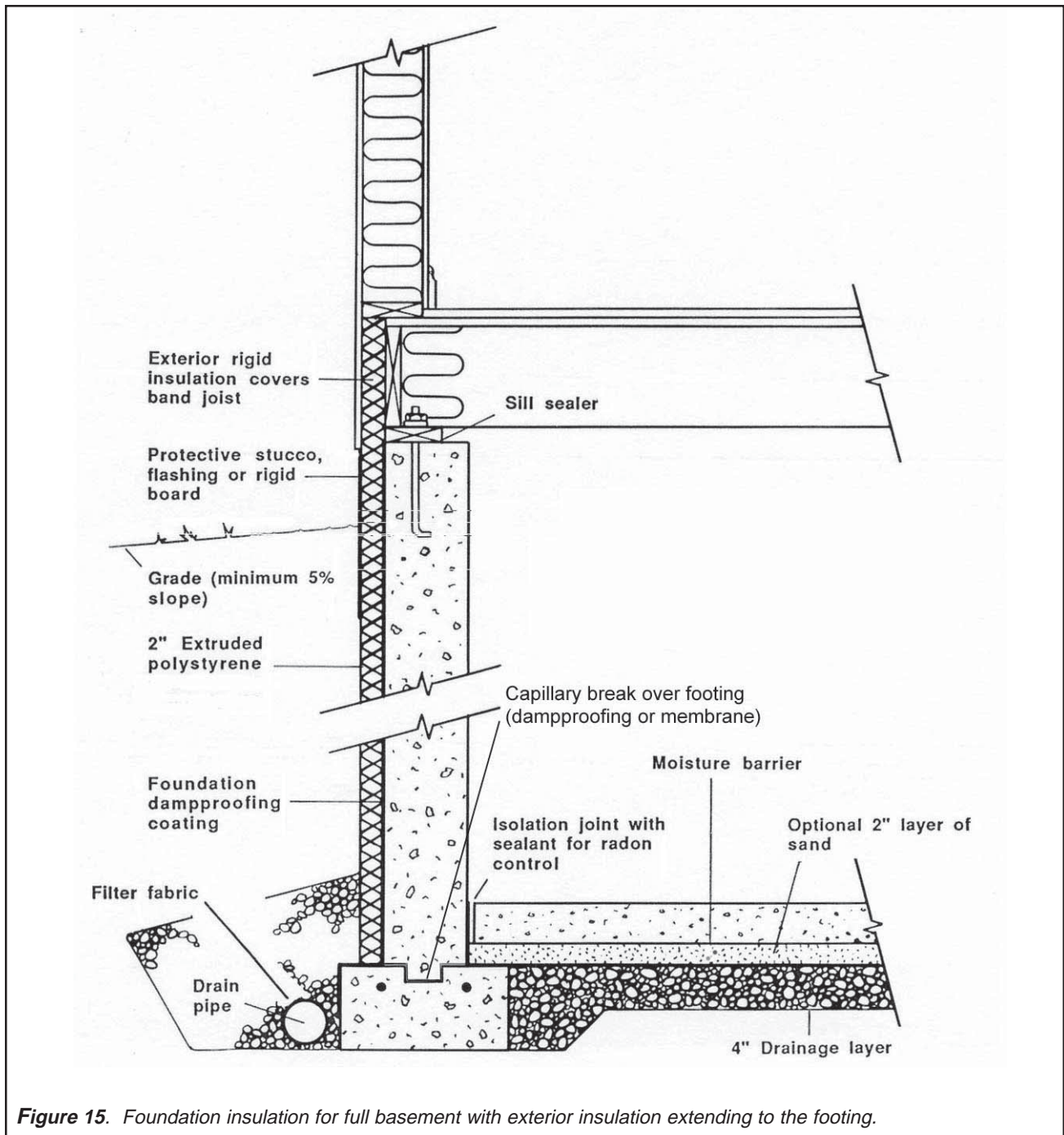

Figure 15. Foundation insulation for full basement with exterior insulation extending to the footing.

specifically for the type of insulation being coated.

In general, the most difficult construction detail is at the top of the wall where the framing begins. In **Figure 15** the band joist is insulated on the outside. In this detail, the wall plate extends out over the floor deck the thickness of the insulation (2" in this case). With 2x6 walls, 3-1/2" of the wall thickness is still resting on the deck, which is adequate. With a 2x4 wall, this detail cannot be used.

Another alternative for exterior foundation insulation is shown in **Figure 16**, with a **water table trim** piece used to extend the wall out to cap the rigid insulation. In this case, the rigid insulation usually only extends up to the top of the foundation wall, so the band joist must be well insulated on the interior, as shown.

Standard foundation construction practices are shown in these illustrations, including a drainage layer of crushed stone under the slab, an isolation joint at the edge of the slab for

radon control (see discussion, pages 22-24), and perforated drainage pipe surrounded by crushed stone outside the footing. Be sure to carefully seal any likely air leakage areas (see pages 15-19).

Use a **saturated foam sill sealer** between the pressure-treated sill and the concrete wall. Because the foam is open-cell, it can be fully compressed, but at gaps where the foam is expanded, the resin within it forms an excellent seal.

Figure 17 shows a different configuration at the band joist. As in **Figure 15**, the band joist is insulated on the exterior with a full two inches, but the 2x6 wall overhangs the floor deck by only one inch. In **Figure 17** the other inch of rigid insulation over the band joist is an extension of exterior rigid insulation on the wall.

Some builders and homeowners like to install an inch of rigid insulation under the basement floor slab as well. This is not required

by the Code, but it will help to make the basement space more comfortable if it is to be used as living space and reduce the potential of condensation on the floor slab.

Figure 17 shows several techniques for controlling radon. The standpipe is a section of 4" PVC pipe extending through the slab and into the 4" layer of crushed stone. The standpipe should be set in place before the slab is poured. After the concrete has set, caulk around the pipe with a high quality caulk that works well with masonry; then cap the pipe. Later, if radon is determined to be a problem, this pipe can be extended out through a wall in the basement or up through the roof and fitted with an in-line fan to depressurize the sub-slab area and prevent radon-laden air from infiltrating the basement. At the edge of the slab,

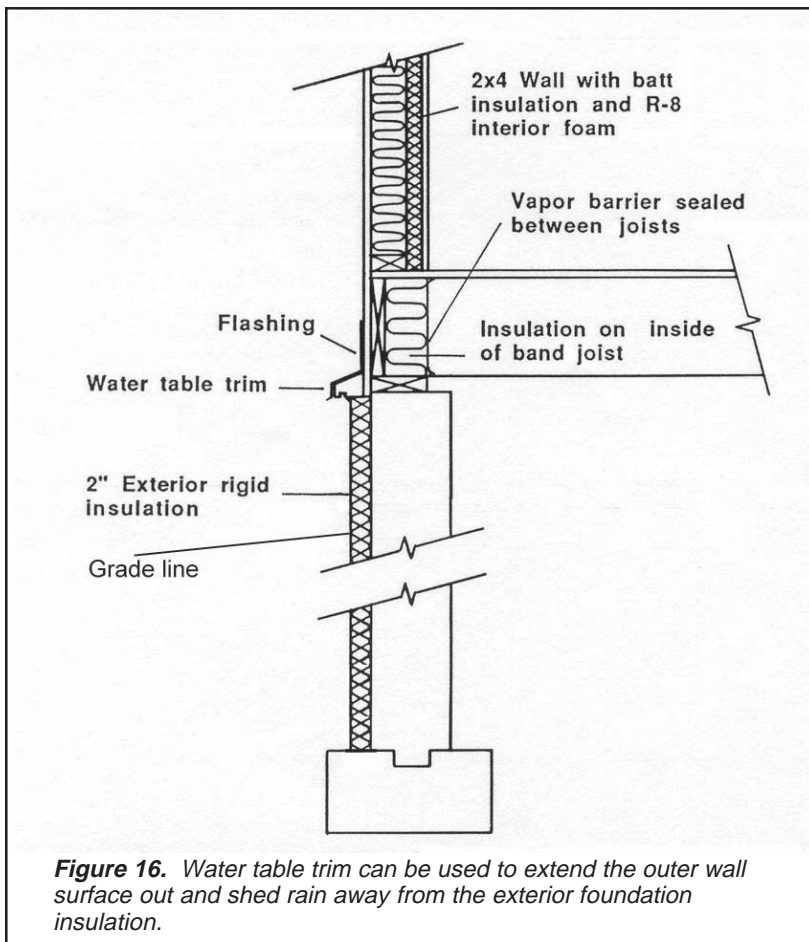

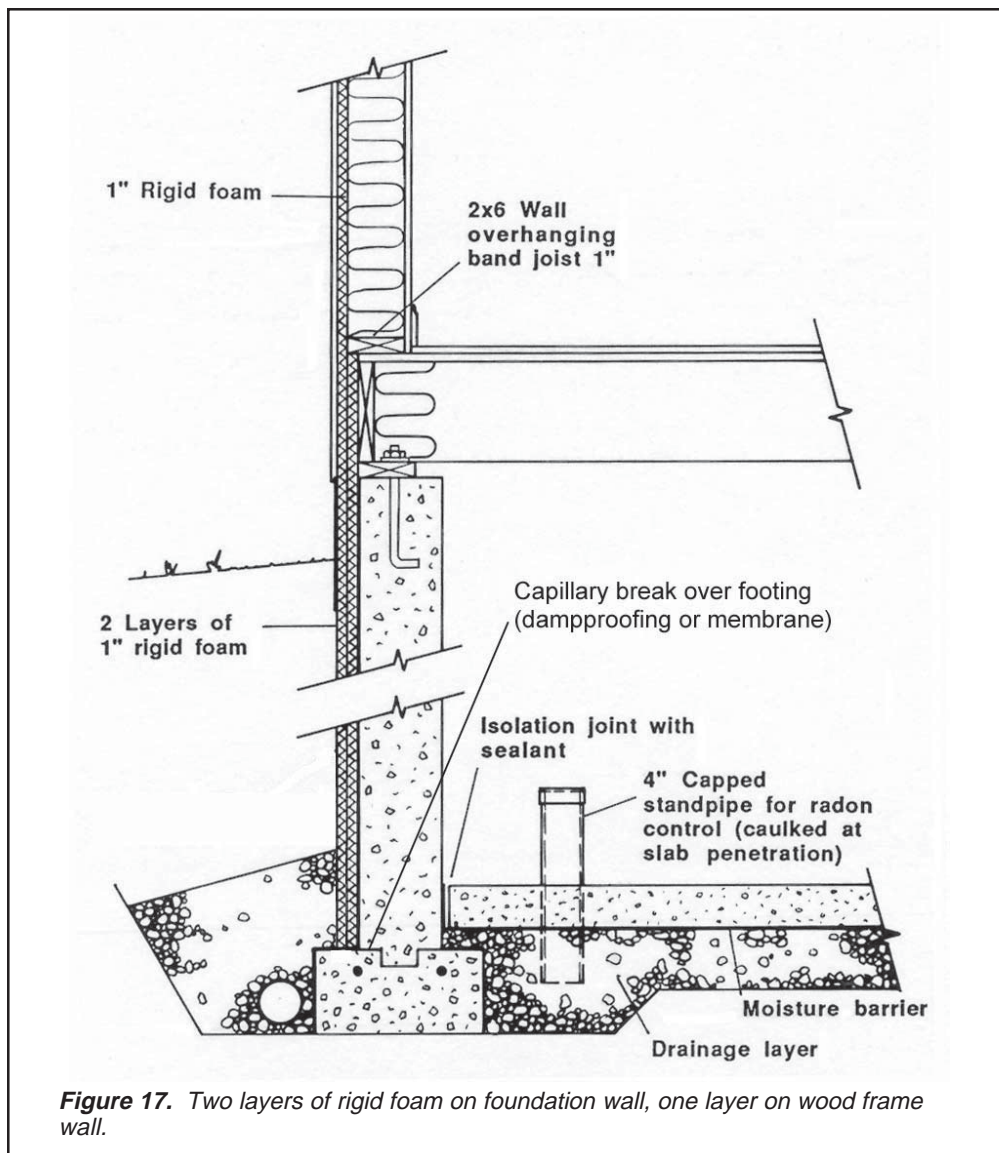

leave a $\frac{1}{2}$ " isolation joint between the slab and foundation wall. After the concrete has cured, seal this gap with backer rod and/or masonry-compatible caulk. *Whenever possible, use poured concrete for foundations rather than hollow block, because the poured concrete is far less permeable to air and radon.*

Interior Foundation Insulation

Although insulating basement foundation walls on the exterior is preferred, there are acceptable ways of insulating walls on the interior.

Foundations insulated on the interior should include a well installed air barrier on the inside to keep air and its contained water vapor away

from the cold foundation wall. However, a vapor barrier should not be used so that the foundation wall can slowly dry to the inside if it gets wet. Even if the foundation interior is insulated with fiberglass between a studs, it is recommended that a layer of extruded polystyrene insulation be installed against the interior face of the wall basement foundation wall.

A detail incorporating *interior* foundation insulation is shown in **Figure 18**. In this case, the wall framing extends to the outside of the floor deck, with the wall sheathing extending down over the pressure-treated sill. A 2x4 wall is constructed on the inside of the foundation wall and insulated with fiberglass batt insulation. Rigid foam insulation is installed between

the interior foundation wall and this framed wall. The top of the frame wall is secured to the underside of the floor joists, as shown. At the band joist, insulation has to be cut and fit between the floor joists. This fills the ends of the joist cavities with fiberglass batt insulation to keep heat from flowing down through the sill and into the concrete. Add fitted pieces of foil-faced rigid foam insulation to the interior of the fiberglass. This rigid insula-

tion is caulked to the floor joists to provide a good air barrier.

Fiberglass insulation can be installed between the studs placed inside the concrete wall. The insulation should be covered on the inside with a carefully installed air barrier. Do not install a vapor retarder or barrier.

Instead of insulating the inside of the foundation wall with fiberglass, you can attach 2" strapping to the wall and install 2"

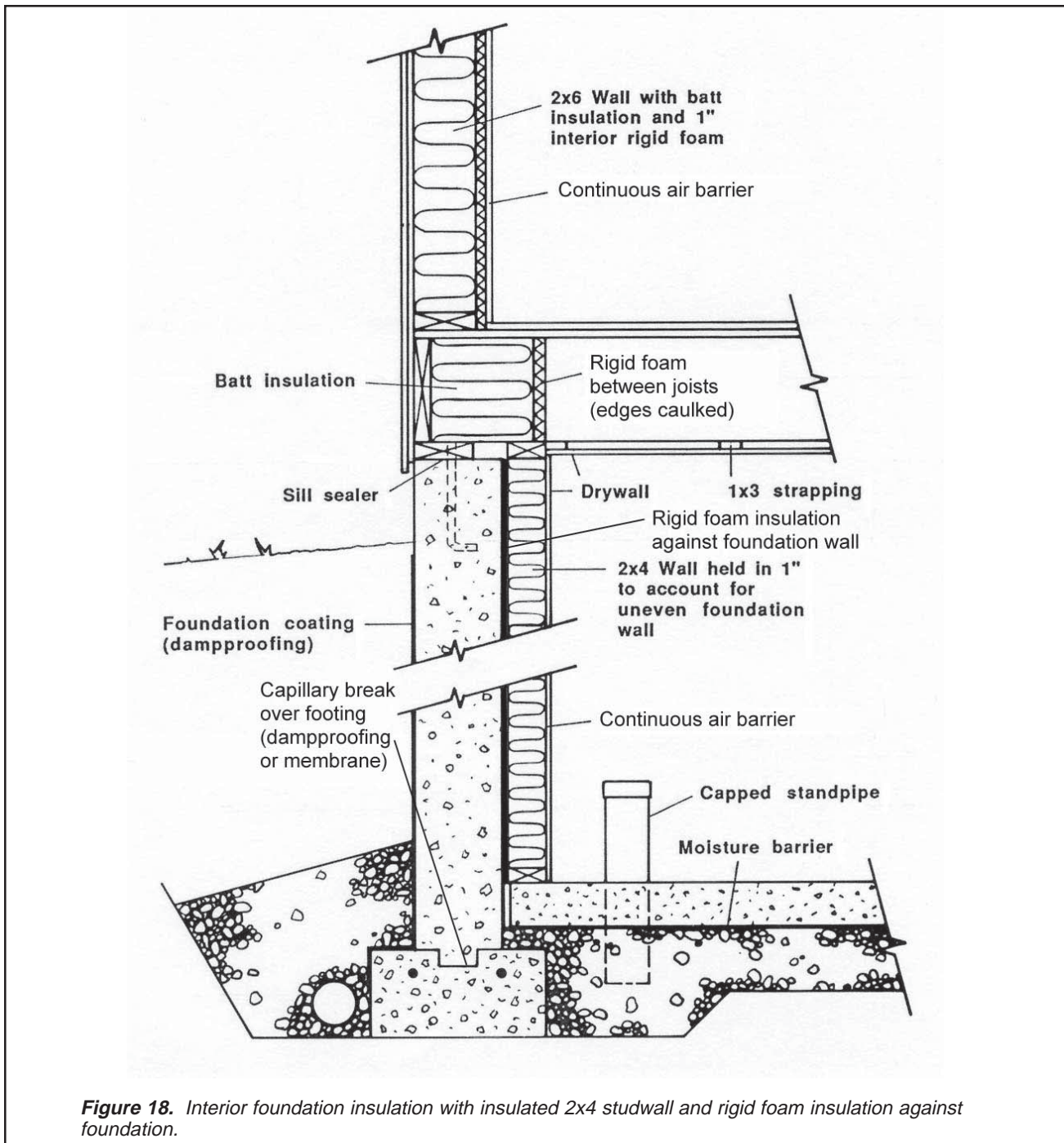

Figure 18. Interior foundation insulation with insulated 2x4 studwall and rigid foam insulation against foundation.

rigid foam insulation between the strapping, as shown in **Figure 19**. The strapping has to be a full 2" deep to be even with the inside face of the foam insulation. Whenever a flammable insulation or air/vapor barrier is used on the inside of a basement wall, a fifteen minute fire-rated material must cover the flammable material. Two common materials that satisfy this requirement are 1/2" drywall and 3/4" plywood.

If an all-weather wood foundation is being used, it should be built and insulated according to American Plywood Association (APA)

specifications. The same minimum R-10 insulation levels are required. Before proceeding with a wood foundation, talk with a building inspector or builder in your area who is familiar with this construction technique.

Slab-on-Grade Foundation

There are a number of insulation options that may be used with slab-on-grade foundations. In **Figure 20**, a full-perimeter frost wall is insulated on the exterior down to frost depth with R-10 insulation. As with the full basement details shown previously, the 2x6

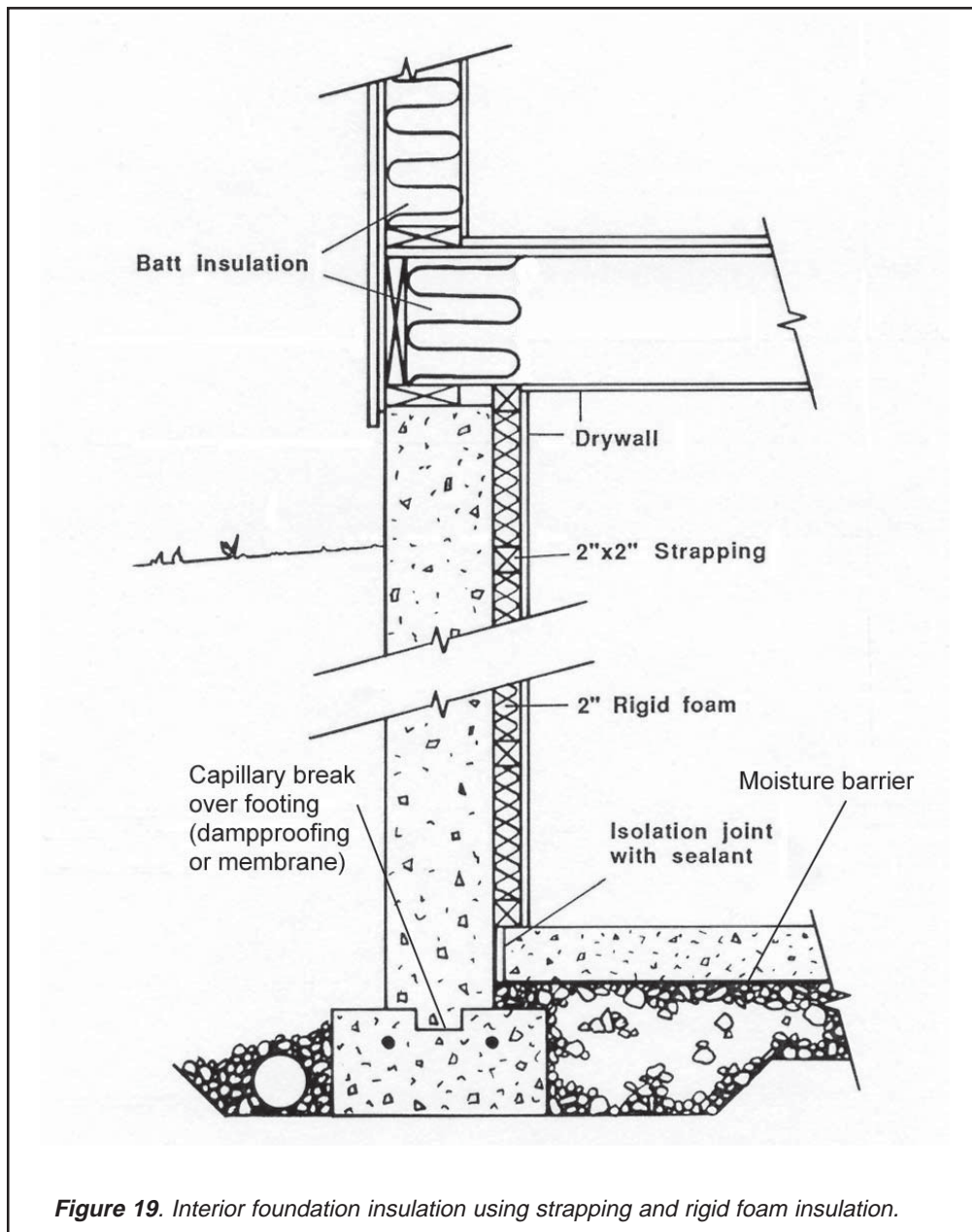

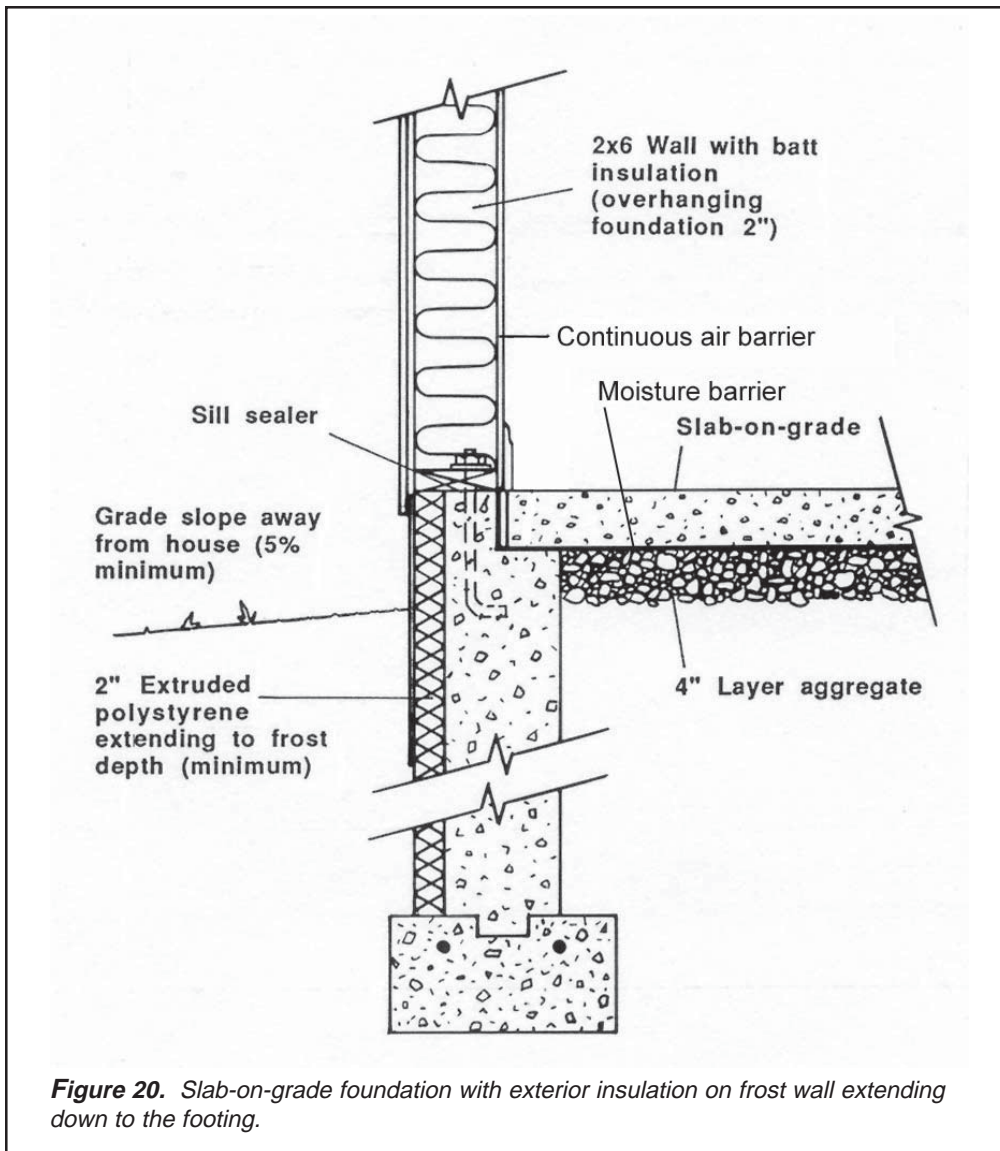

wall can either overhang the foundation, or water table trim can be used to extend the wall 2" out at the foundation level. As long as the exterior frost wall insulation extends down to frost level, insulation under the slab is not required by the Code. However, if this insulation is installed, it will make the floor temperature more comfortable.

In **Figure 21**, 2" extruded polystyrene insulation covers the perimeter edge of the slab and then extends under the slab for a distance at least as great as the frost depth. The insulation may extend under the full slab, but this is not required.

As an alternative, the rigid insulation may cover the above-grade perimeter and then

extend diagonally outward from the frost wall for a distance at least as great as the frost depth.

In **Figure 22**, the rigid insulation covers the perimeter edge of the slab, then extends down along the *inside* of the frost wall to the footing (frost depth).

Finally, with a monolithic floating slab, the insulation should cover the perimeter edge of the slab/footing and then extend under the slab for a distance equal to the frost depth, as shown in **Figure 23**. As mentioned previously, the detail for slab-on-grade construction, and especially monolithic slabs, R-10 insulation must be used in one of two configurations: 1) either around the full perimeter extending down

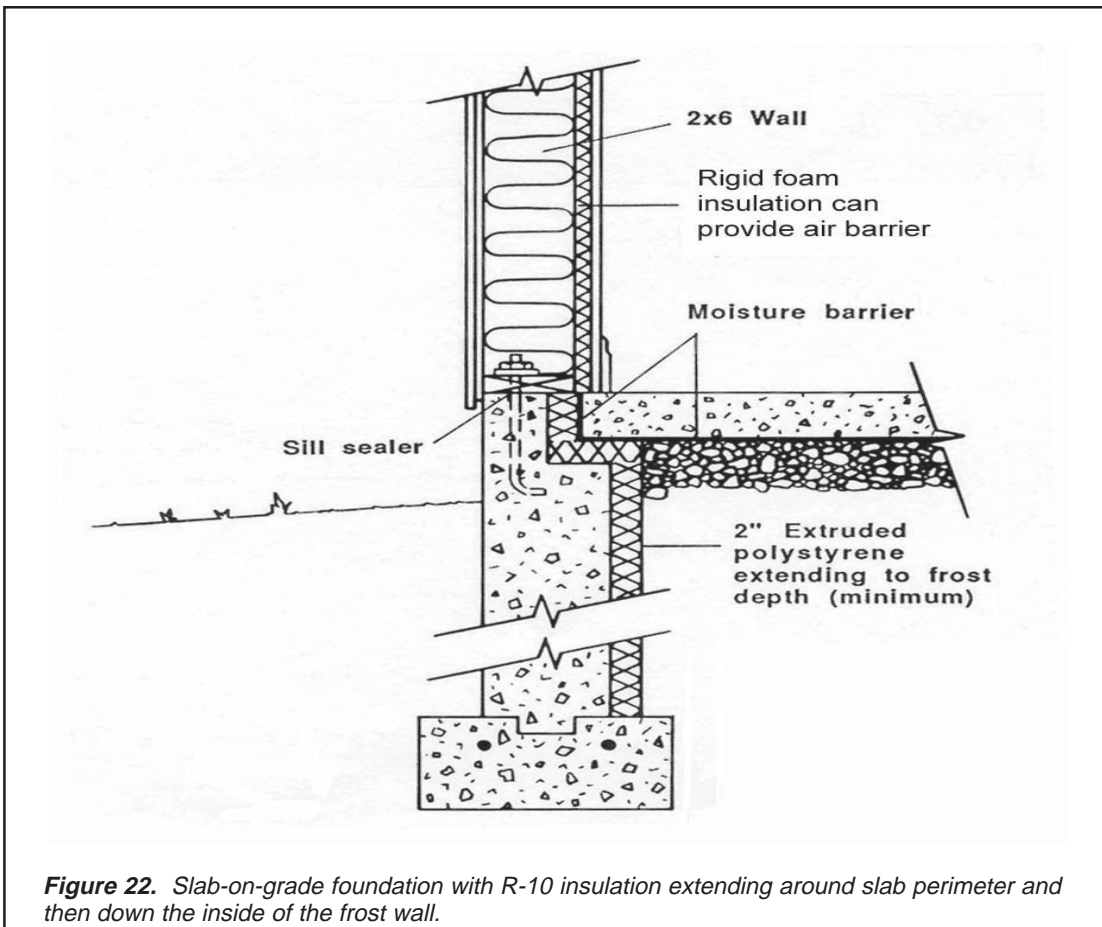
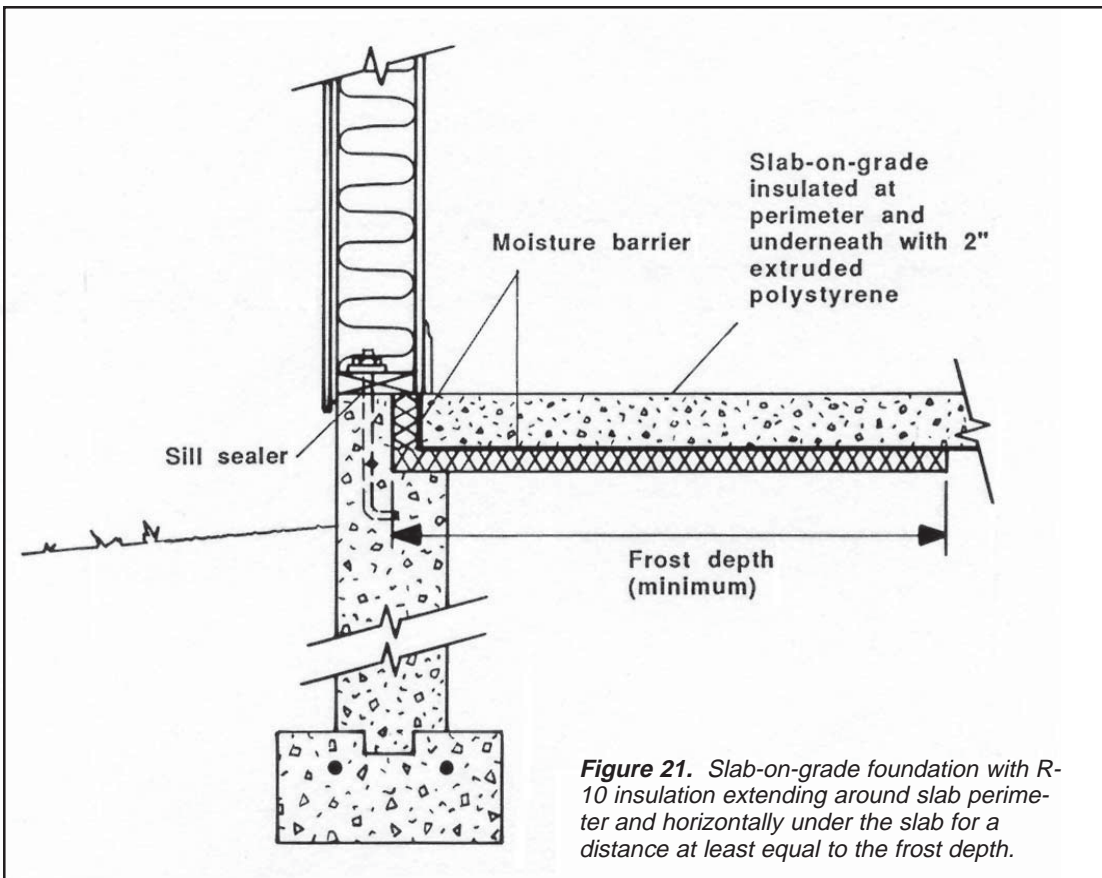

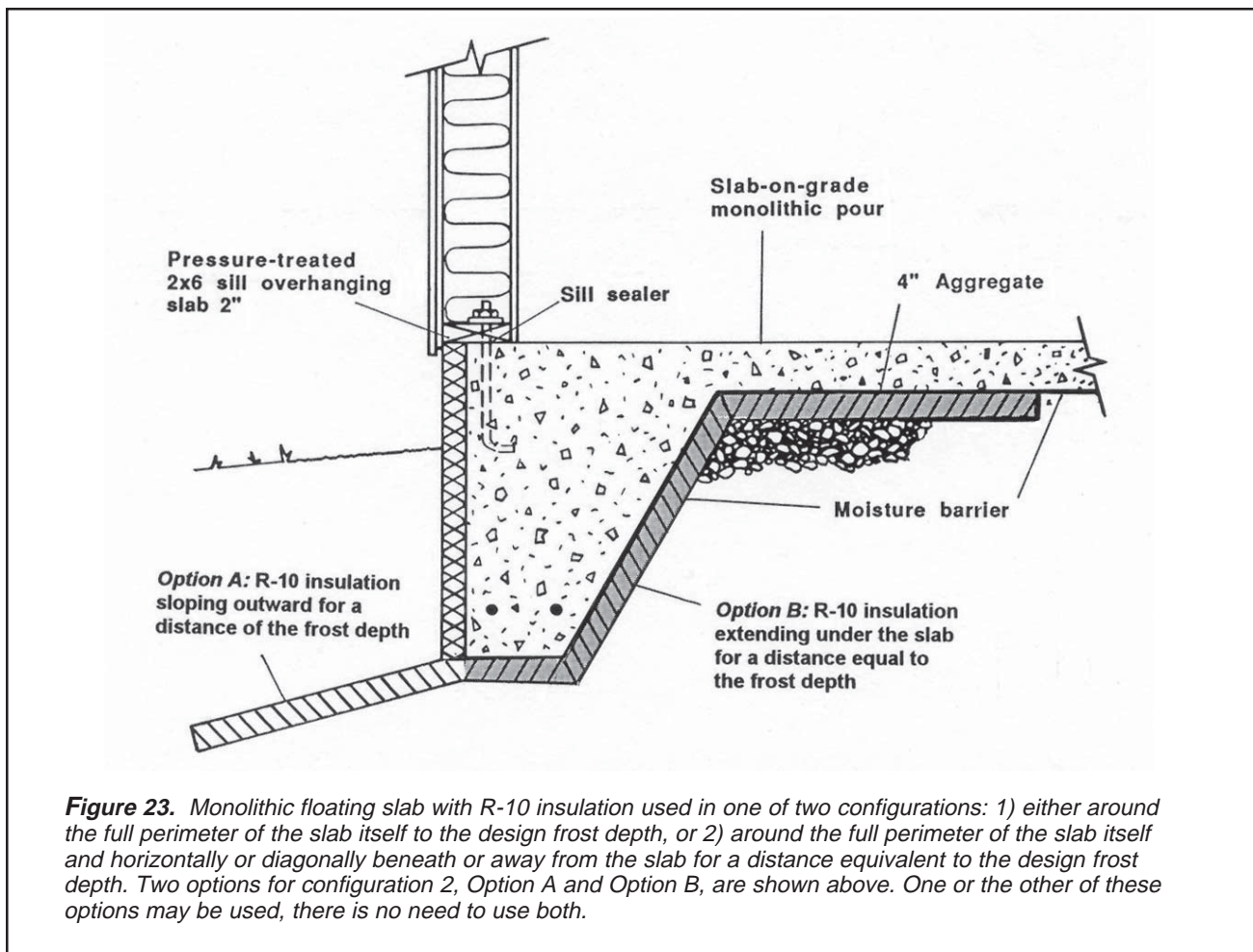

to the design frost depth, or 2) around the full perimeter of the slab itself and horizontally or diagonally beneath or away from the slab for a distance equivalent to the design frost depth.

Crawl Space Foundation

If the house is to have a crawl space, conditioned crawl spaces are insulated using basically the same methods used for full foundations: with either exterior or interior insulation extending down to the frost depth. Because exterior or interior insulation used for this purpose is in contact with the ground, use rigid extruded polystyrene.

Perimeter insulation of crawl spaces performs better than insulating the crawl space ceiling. The crawl space is likely to stay dryer and this allows for the installation of heating and plumbing equipment in the space.

If the crawl space area must be cut off from the thermal envelope by insulating the crawl

space ceiling, the house should be sealed from the crawl area as well as possible. Additionally, no heating or plumbing equipment should be installed in the crawl space.

Because most houses built in Maine have a high likelihood of airborne radon, sub-slab type ventilation is recommended for crawl spaces. The air can be pulled from under a sealed polyethylene ground cover instead of a floor slab, as it would be in a basement.

2. Floors over Unheated Spaces

Although it is preferred to include basements and crawl spaces within the thermal envelope of the house, this is not appropriate for some houses. **Figure 24** shows a typical detail for a floor above an unheated crawl space. The Maine Model Building Energy Code calls for a minimum of R-21 for floors over unheated spaces according to the prescriptive requirements.

An air barrier should be installed on the warm side of the floor. It is also recommended that an air barrier be provided by rigid insulation installed over the bottom edges of the floor joists. Taping or sealing the joint will provide another air barrier and prevent wind washing of the fibrous insulation in the floor joist cavities.

The fiberglass floor insulation can be held in place with wire, strapping or by other appropriate methods. If using kraft faced fiberglass, the facing must be installed upward, toward the heated space.

When planning a ceiling above a basement, think about whether the basement might be

finished off as a living area in the future. If so, it might be worth spending the extra money during construction to insulate the space as if it were heated.

If operable vents are installed in the crawl space, you need at least an 8" x 16" vent for every 350 ft² of crawl space floor area, with a minimum of two vents for adequate cross-flow. The vents should have screens and covers so that they can be closed during the winter months. Please see page 30 for a discussion about the usefulness of crawl space vents. To keep moisture from seeping up from the ground, place a sheet of 6-mil polyethyl-

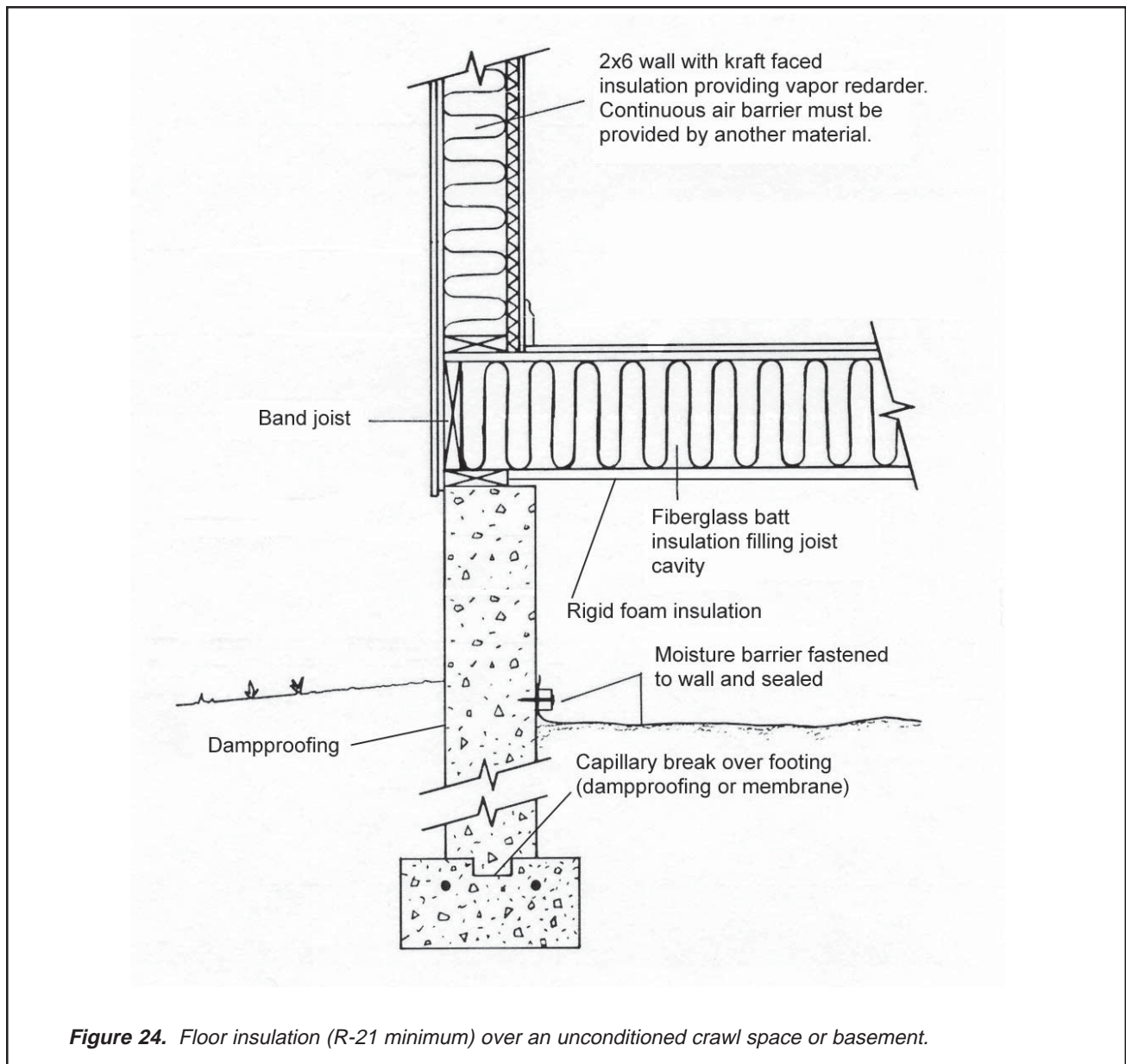

Figure 24. Floor insulation (R-21 minimum) over an unconditioned crawl space or basement.

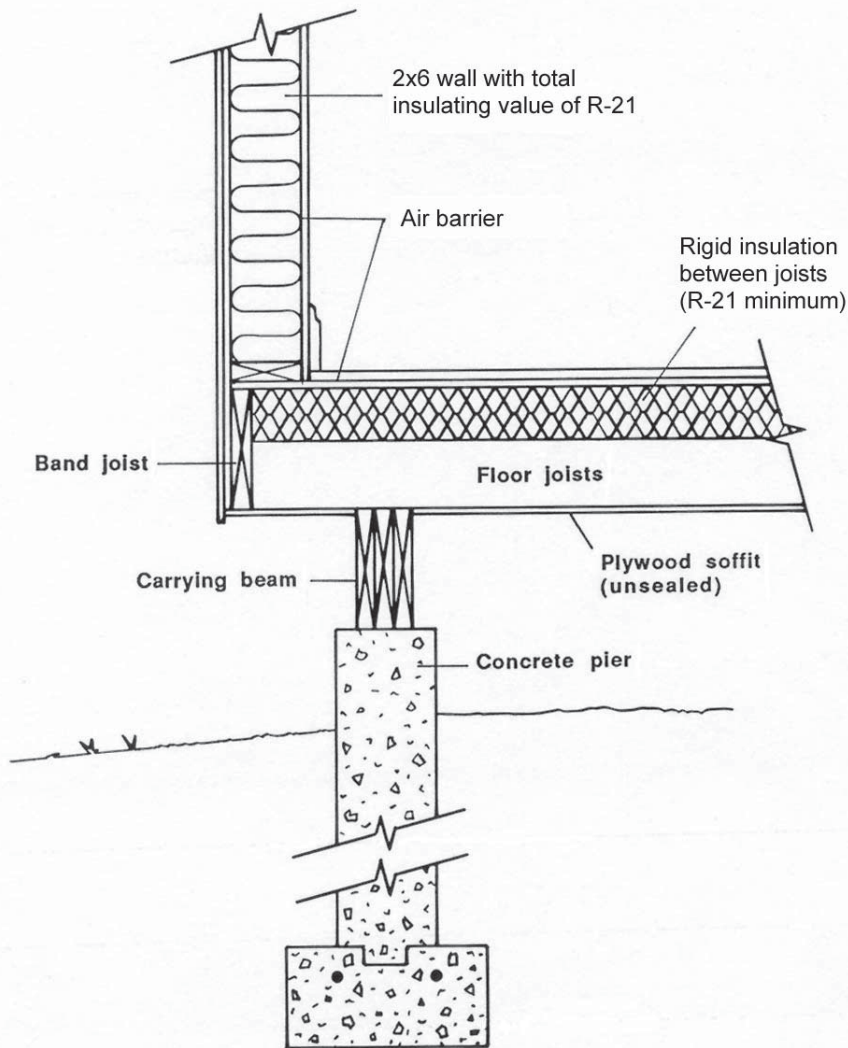

Figure 25. Pier foundation with expanded polystyrene insulation fitted between floor joists.

ene on the ground, and fasten it (there is no need to seal it) to the frost wall 6 inches up above the ground level. If the crawl space is to be used at all, protect the plastic with single-coverage rolled roofing.

If the house is to be built on piers, the same insulation details can be used as with a crawl space, except that the floor joists should be covered on the underside because they will be more exposed to the elements. The insulation can be either fiberglass or rigid insulation, as long as the total insulating value is at least R-21. Use of rigid insulation is shown in **Figure 25**. With fiberglass batt insulation, it generally makes sense to completely fill the

joist cavity, even though it will provide more than the required R-21.

Overhanging floors must also be insulated to at least R-21. A typical detail with 2x10 joists and 2x6 walls is shown in **Figure 26**. In this case, R-30 fiberglass is used, filling up the entire joist cavity. Sealed and taped rigid insulation should then be installed just below the joists before the finished material is installed. Blocking should be installed close to the inside of the lower wall; insulation is installed in the overhanging floor to the blocking. Caulk the blocking where it rests on the wall top plate, where it abuts floor joists, and where the subfloor above rests on it.

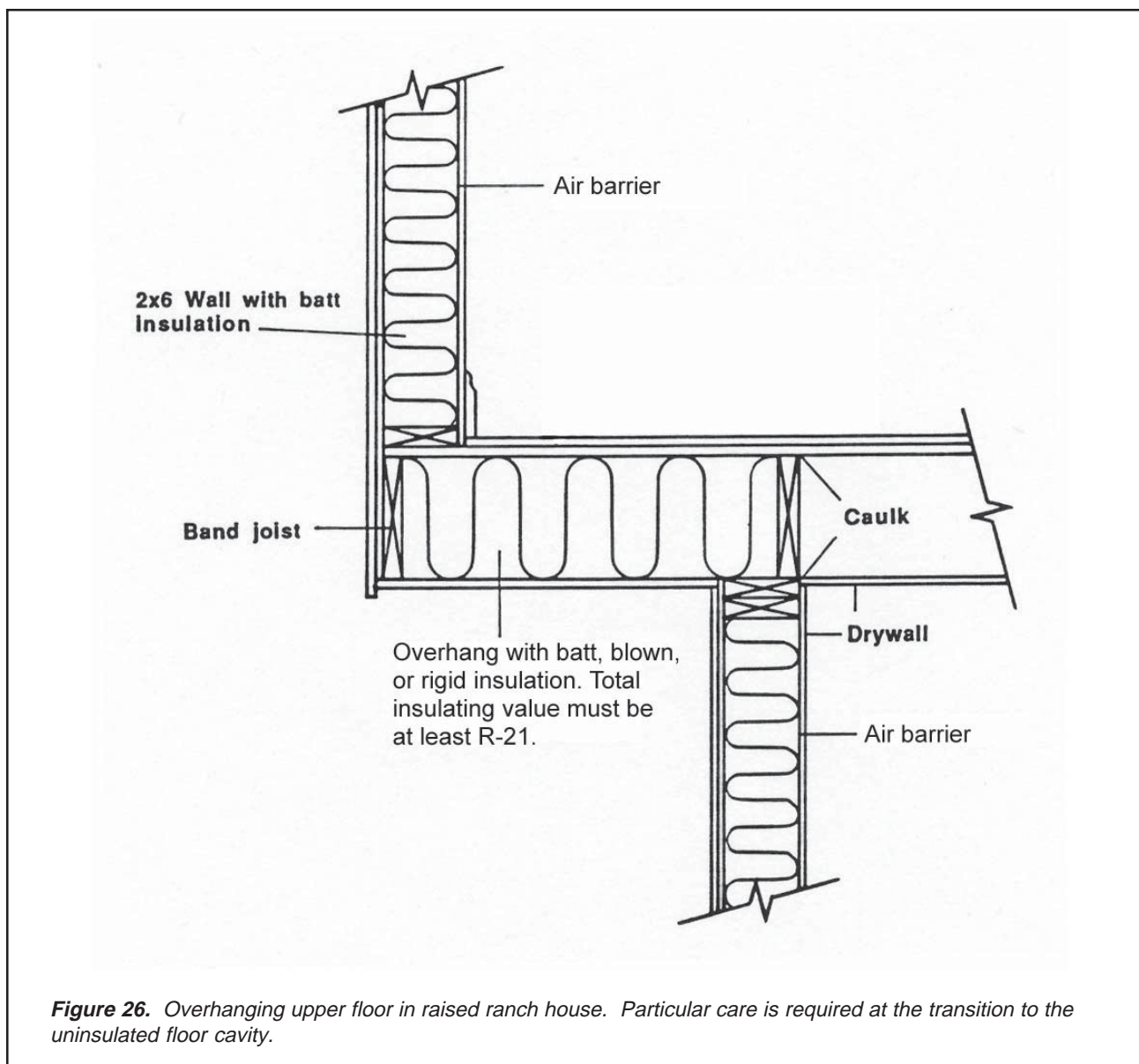

Figure 26. Overhanging upper floor in raised ranch house. Particular care is required at the transition to the uninsulated floor cavity.

Install an air barrier on top of the subfloor of the overhanging section and on the inside of both exterior walls.

3. Walls

Exterior walls must be insulated to a minimum of R-21 in order to comply with the Code. The most common technique for achieving this is to build the exterior walls with 2x6s rather than 2x4s and insulate with R-21 fiberglass batts. Other cavity-fill insulation may be used if it has at least an R-21, as shown in **Figure 27**.

Because 2x6s offer greater strength than 2x4s, you have the choice of framing at 24" on center (o.c.) rather than at 16" o.c., which is

required with 2x4 walls. Even with 2x6s, some builders prefer to use 16" o.c. so that 1/2" drywall will feel more solid. Other builders frame at 24" o.c. and use 5/8" drywall.

If you choose to build with 2x4s, the Maine Model Energy Building Code can be met by adding a layer of rigid foam insulation on either the inside or the outside of the studs, as shown in **Figure 28**. If you use standard fiberglass batts providing R-11, the rigid insulation must be at least R-10 for example, 1 1/2" of polyisocyanurate insulation or 2" of extruded polystyrene.

An important question is whether to put rigid foam insulation on the inside or the outside

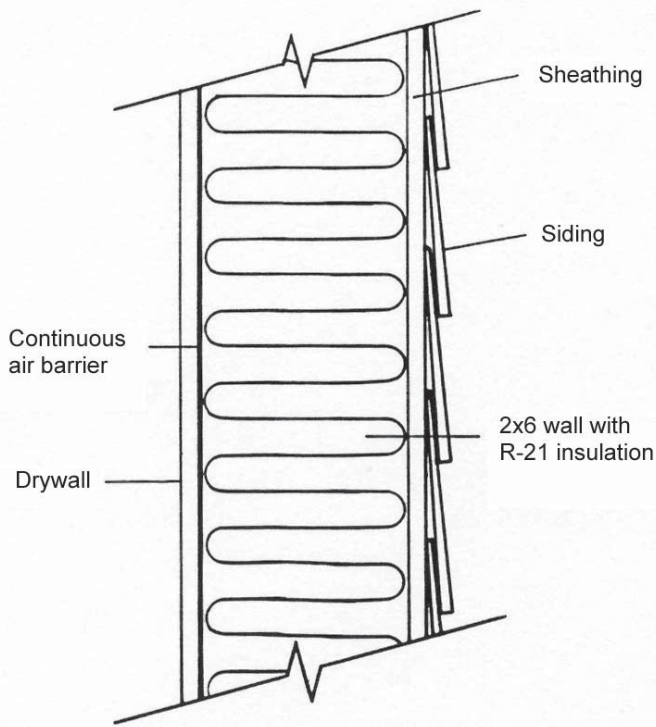

Figure 27. Standard R-21 wall section using 2x6 studs and cavity-fill fiberglass or cellulose insulation.

of the framed walls. By installing the foam on the inside, the foil facing can act as the vapor barrier (as long as the edges are properly taped). Those who prefer the rigid foam on the outside argue that it provides a more complete barrier to heat loss, uninterrupted by interior partition walls where they connect with the exterior walls. However, this approach raises several issues.

Putting foam insulation on the outside, particularly if it is foil-faced, will work as long as there is no vapor barrier installed on the warm side of the wall. However, a vapor *retarder* such as kraft facing in fiberglass or vapor retarder paint should be used

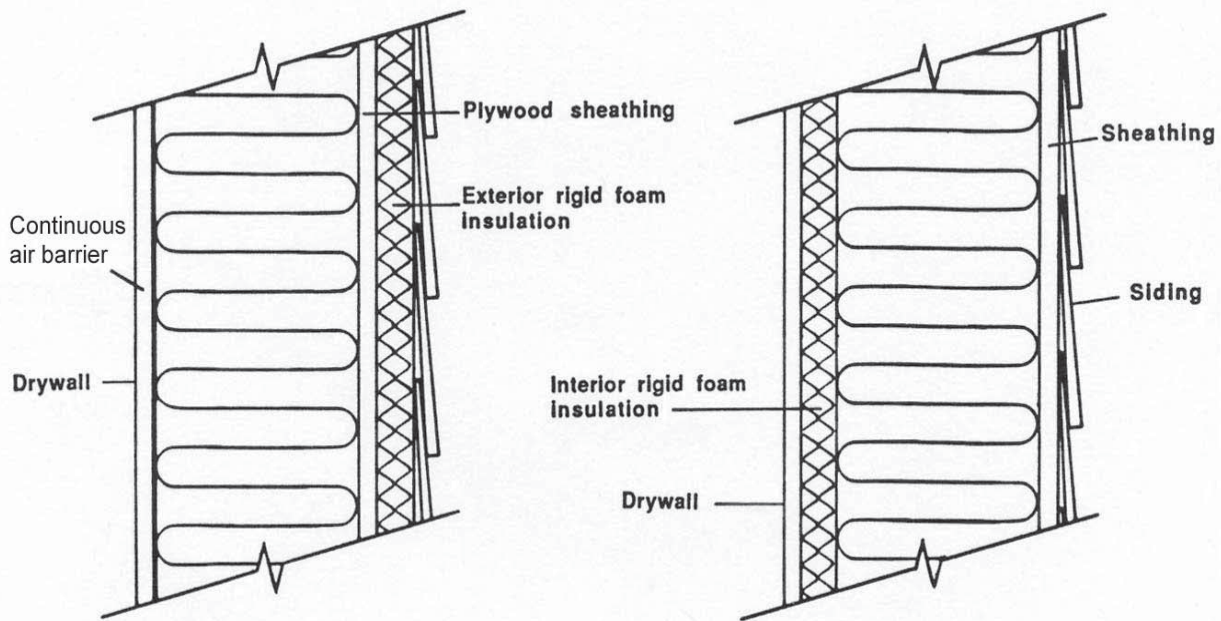

Figure 28. Rigid foam insulation can be installed on the inside or outside of the wall. While putting it on the outside is more common, more and more builders have begun putting it on the inside for various reasons. With a layer of rigid foam, the R-21 wall insulation requirements can be satisfied with a 2x4 wall.

on the warm side. To provide adequate racking strength with exterior foam insulation, either use let-in metal bracing (when the foam is installed directly against the studs), or install the plywood sheathing against the studs and the foam to the outside of the sheathing.

With rigid foam insulation on the exterior, there is also some concern about damage to the siding. High rates of expansion and contraction during the daily cycles and high temperature buildup may weaken wood siding and reduce the durability of paints. For this reason, when using exterior foam insulation, it is strongly recommended that vertical strapping be installed under the siding to provide a

channel for air flow—sometimes called a **vented rain screen**—as shown in **Figure 29**. The air space should be screened at the top and bottom. This vented rain screen also prevents driving rain from penetrating into the interior portions of the wall cavities.

When only cavity-fill insulation is used in the wall system, a considerable amount of heat is lost through the studs. For this reason, it makes sense to plan corners and interior partition wall intersections carefully. **Figure 30** shows corners and partition wall intersections that result in a minimum of bypass heat loss through the wood. Three studs make up the corner detail, providing a complete nailing

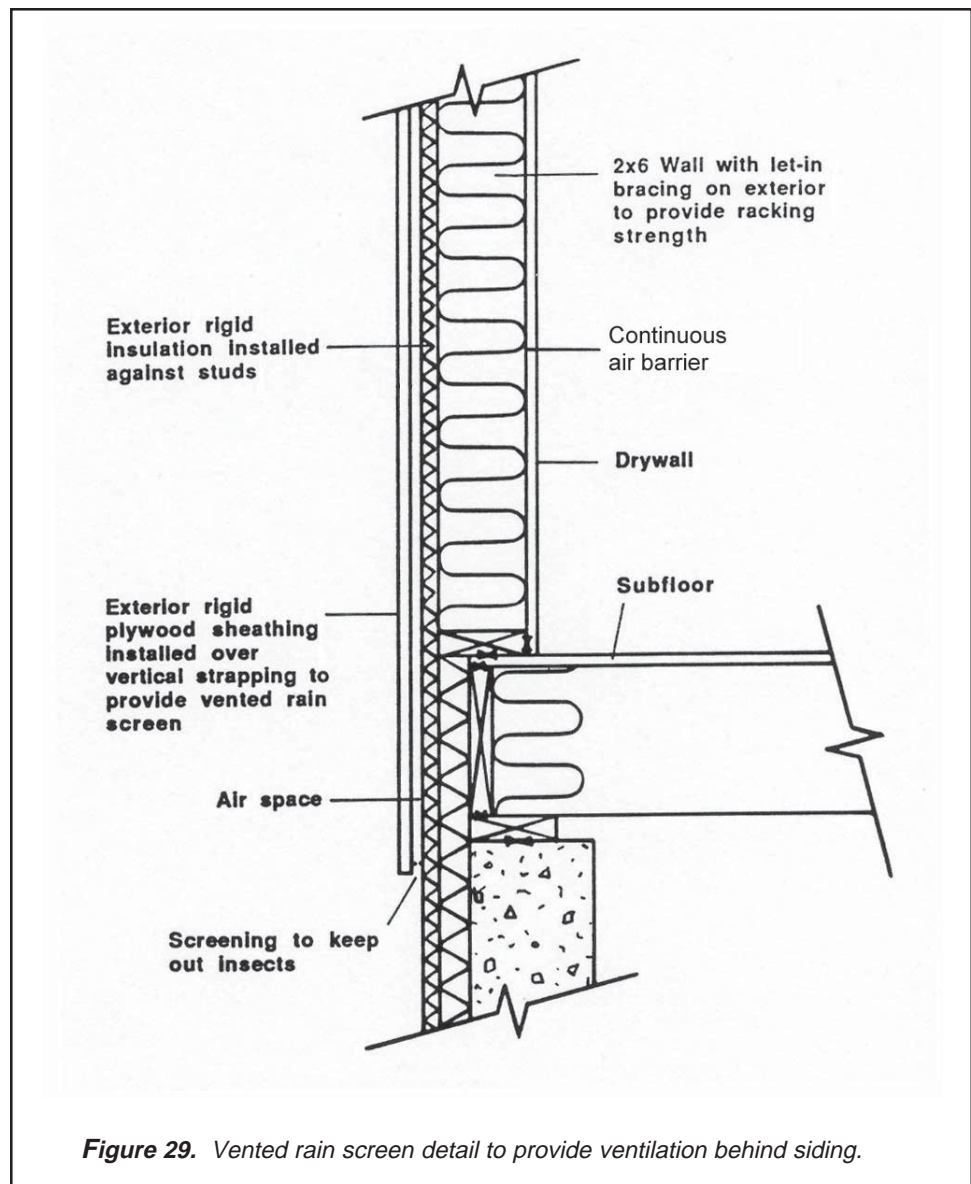
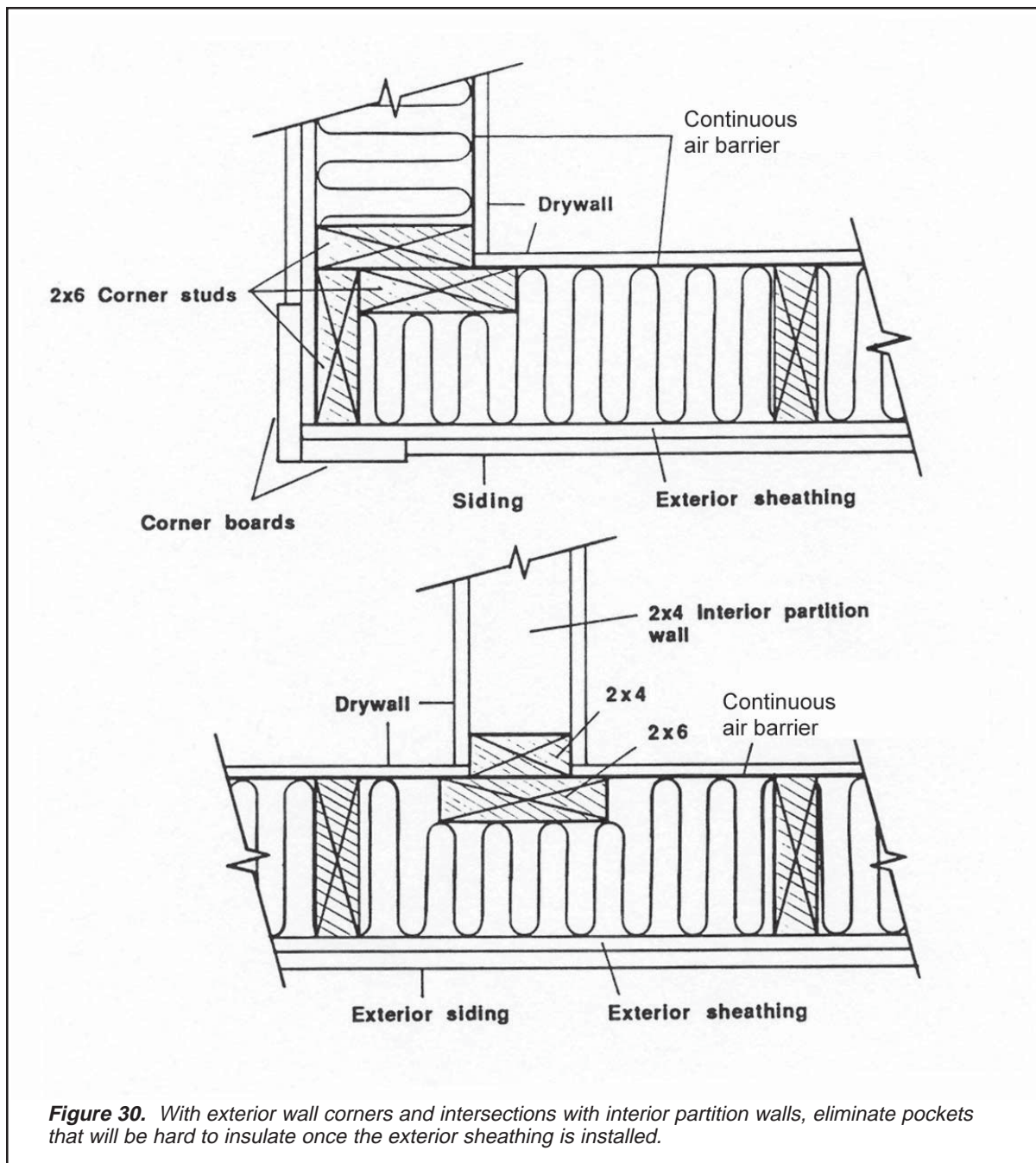

Figure 29. Vented rain screen detail to provide ventilation behind siding.

base for drywall and plywood sheathing. Most importantly, you don't end up with a hidden pocket that is difficult or impossible to insulate after sheathing is installed.

Where 2x4 interior partition walls intersect with exterior walls, a 2x6 can be placed sideways, centered on the 2x4 wall. This option provides a 1" nailer on both sides of the 2x4 wall for drywall and does not produce a hidden pocket in the exterior wall that is difficult to insulate (see **Figure 30**). This technique also uses one less stud than conventional partition-wall intersections use.

The details used at the bottom of the first-floor wall will depend on the foundation



insulation configuration. Refer back to the foundation section (page 39) for appropriate details.

Where upper floors intersect with exterior walls, the band joists also need to be insulated. Either fiberglass batts or blocks of rigid foam insulation (or both) can be installed against the band joist between the second-story floor joists, as shown in **Figure 31**. Make sure that the details for this work include a good air barrier between the indoors and outdoors.

If rigid foam sheathing is used on the outside of the wall, you do not need as much insulation on the inside of the band joist, as shown in the bottom illustration of **Figure 31**. Because of the possibility of moisture problems, do not install foil-faced foam on both the outside and inside of the band joist. If the exterior walls are being insulated with wet-spray cellulose or another spray-in-place insulation product, these joist spaces can easily be insulated at the same time.

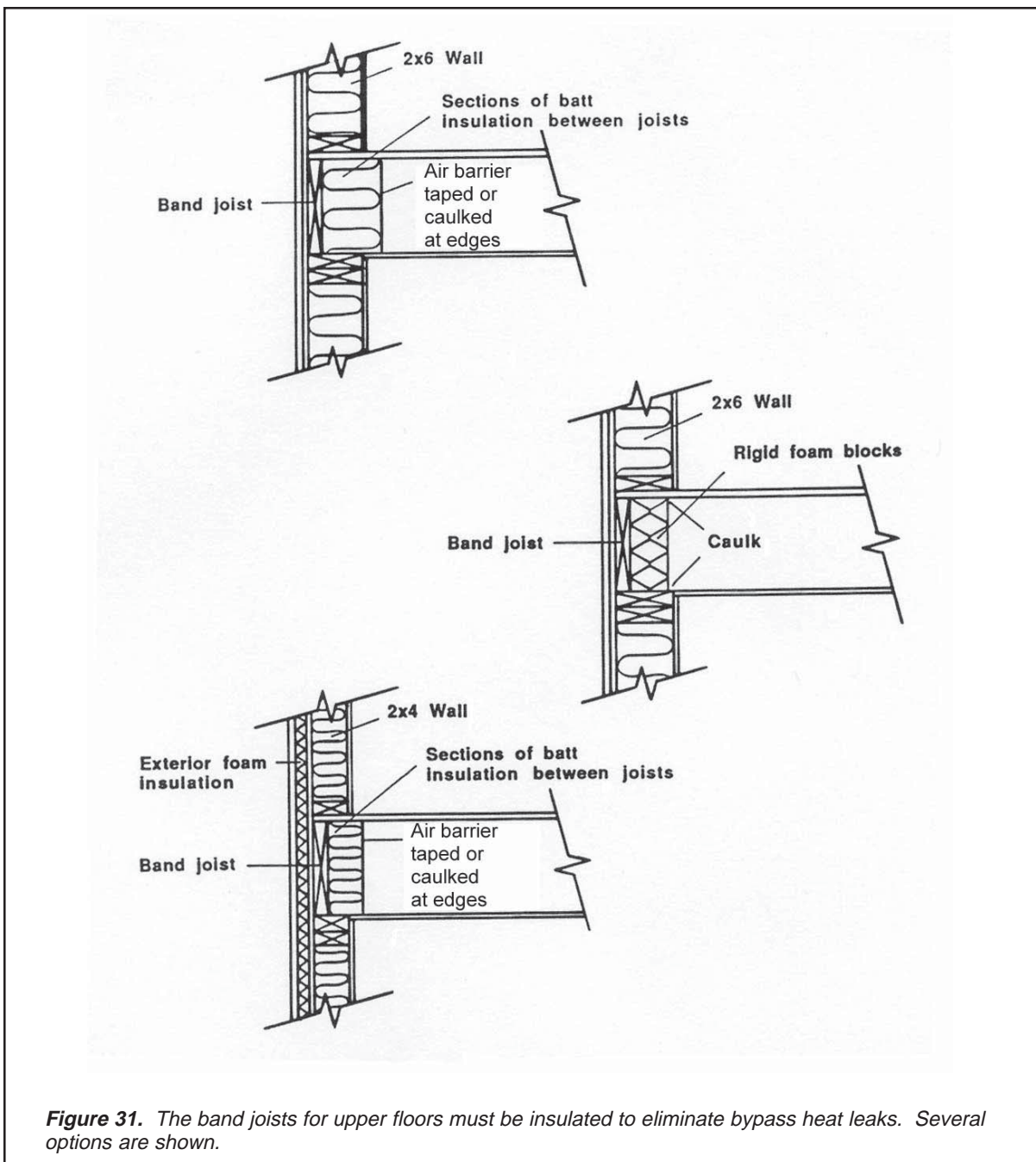

Figure 31. The band joists for upper floors must be insulated to eliminate bypass heat leaks. Several options are shown.

When constructing headers over windows and doors, allow for insulation between the framing members, as shown in **Figure 32**. The space between the two headers can be filled with batt or rigid insulation. If rigid insulation is used, the headers can be prefabricated (depending on the header span and structural loading, the headers may need to be solid wood, allowing no space for insulation).

Be sure to leave $\frac{1}{2}$ " inch at the window and door rough openings to accommodate foam sealing around the window and door jambs (see

discussion on installing windows and doors, page 65).

4. Roof Details Insulated Flat Ceilings

The Code calls for ceilings to be insulated to R-38 or R-49. This requirement applies to both flat ceilings beneath unheated attics and sloped ceilings.

With unheated attics, when the flat ceiling is to be insulated, providing R-38 is relatively

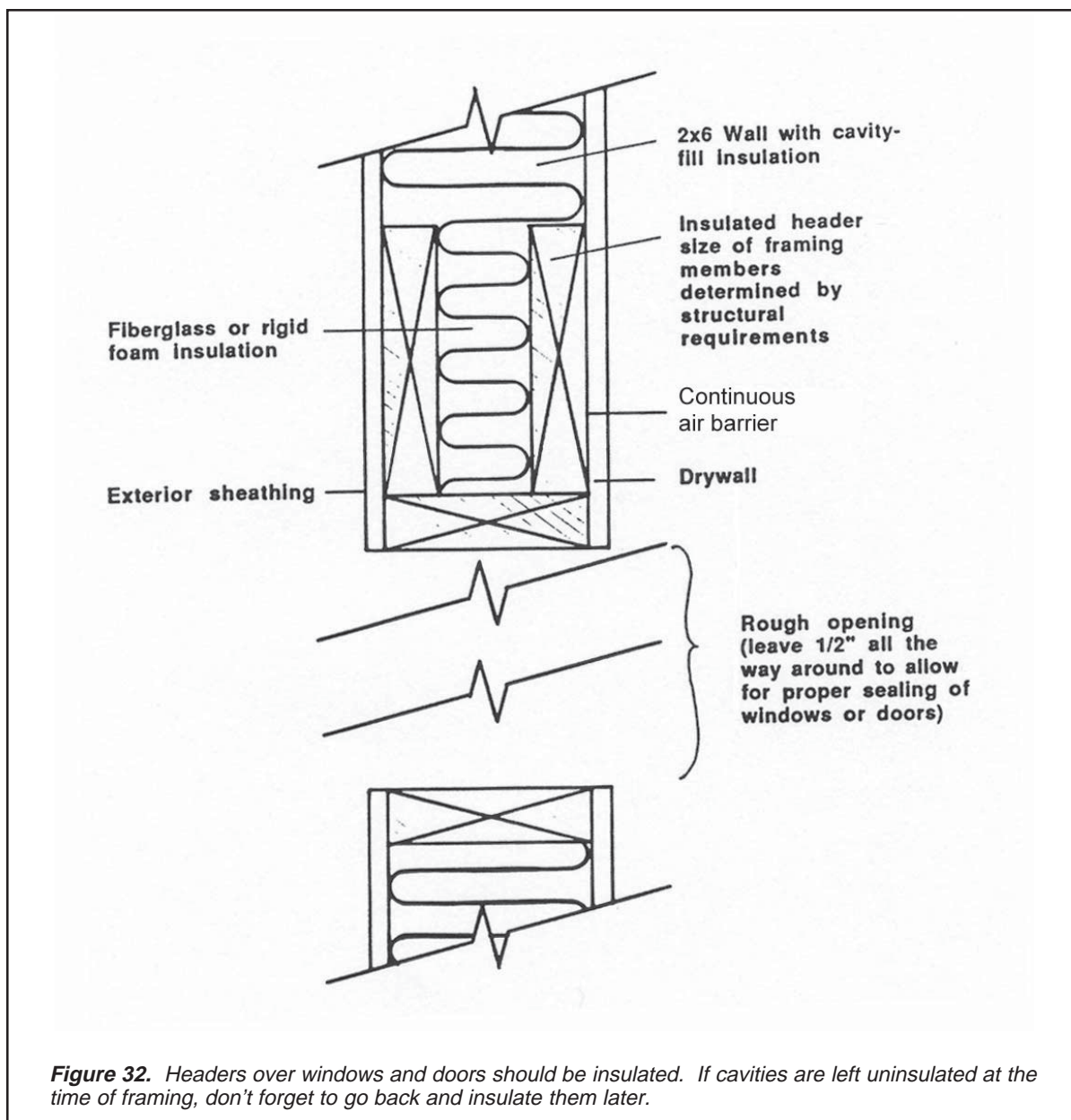

easy. If loose-fill cellulose or fiberglass are being used, a 12" nominal thickness is required (if R-49 is required, other options must be used). Because the full depth of insulation cannot be installed at the roof edge when it is framed in the conventional manner (see **Figure 33**), the Code allows the insulation to be reasonably compressed at the eaves.

If you modify the roof framing, however, it will not be necessary to compress the insulation at the eaves. As shown in **Figures 34** and **35**, the rafter bottoms can be raised and cut to fit onto a **rafter plate** on top of the ceiling joists, rather than resting directly on the wall top plate.

This technique provides enough space for both full-thickness R-38 insulation and an air channel above the insulation. Depending on the thickness of the ceiling joists, the loose-fill or batt insulation may come up to the top of the joists or may fully cover them. If relatively small joists are used, make sure some insulation is placed over the upper rafter plate.

If you are using loose-fill cellulose or fiberglass to insulate the flat ceiling, install a baffle to keep the insulation from falling down into the soffit where it can restrict air flow into the soffit vents. Even with batt insulation, a baffle is a good idea because it will help reduce

air flow *through* the insulation—wind washing—which can reduce its effective R-value. For the baffle, you can nail sections of plywood to the wall sheathing between the rafters to contain the insulation, as shown in **Figure 35**, or use rigid insulation to accomplish the same effect.

If 2x12 or 2x10 joists are used, a baffle may not be necessary—the rafter plate and wall sheathing should adequately contain the insulation and prevent wind washing. If there is the chance that the insulation will completely fill the space under the roof sheathing near the eave (unlikely with the raised rafters), vent spacers should be installed against the roof sheathing at the eave area.

If using roof trusses for insulated flat ceiling systems, you can solve the problem of compressed insulation at the eaves in one of two ways, shown in **Figure 36**. You can specify either **raised-heel trusses** or **cantilevered trusses**, which extend out over the walls. (The insulation depth achievable at the edge of the wall depends on the roof pitch and extent of overhang.) With raised-heel trusses, you may be able to extend the wall sheathing all the way up to the rafter chord of the truss, as shown.

Insulated Sloped Ceilings

Achieving R-38 or greater with insulated cathedral ceilings is more difficult than it is with flat ceilings. Depending on the rafters used, you

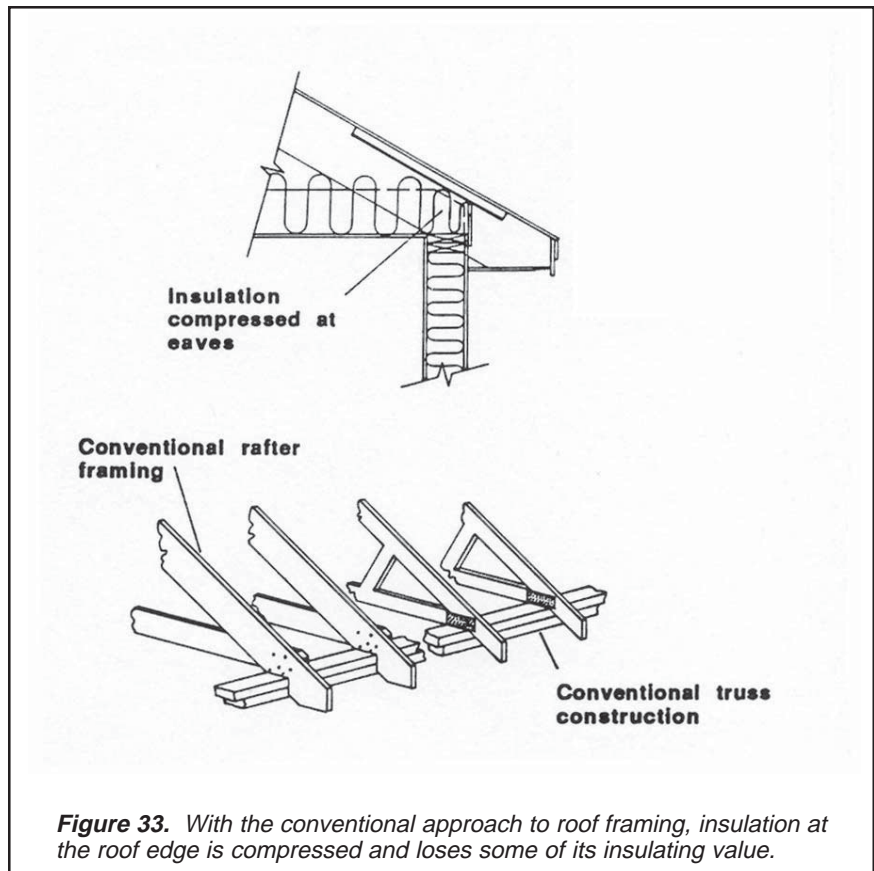

Figure 33. With the conventional approach to roof framing, insulation at the roof edge is compressed and loses some of its insulating value.

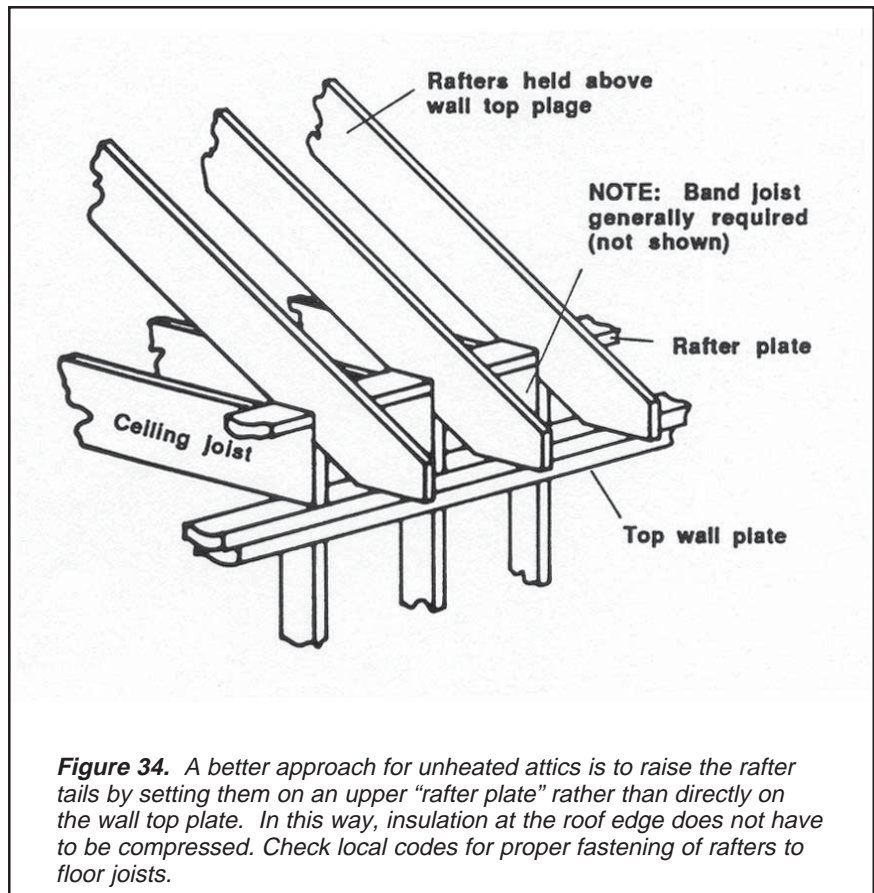

Figure 34. A better approach for unheated attics is to raise the rafter tails by setting them on an upper "rafter plate" rather than directly on the wall top plate. In this way, insulation at the roof edge does not have to be compressed. Check local codes for proper fastening of rafters to floor joists.

may need to use a combination of batt insulation and rigid foam insulation.

In the simplest complying roof (shown in **Figure 37**), rafters are used with fiberglass batt insulation compressed to fit snugly against vent spacers under the roof sheathing. The vent spacers are necessary to allow air flow up along the roof sheathing from soffit to ridge vents. In this detail, blocking is cut and installed between the rafters against the top wall plate to hold the insulation in place and funnel the air up over the insulation. The blocking or baffle is very important, even with batt insulation, because it keeps the air from flowing through the insulation. This airflow reduces the effective R-value and may cause moisture problems. The blocking or baffle should extend up to the vent spacers.

If you are using rafters smaller than 2x12,

you will need to add additional insulation to meet the required R-38 or higher. While false rafters and batt insulation can be used to bring the insulation level up to R-38, the most common strategy is to use a layer of rigid insulation on the inside of the roof/ceiling assembly. When using 2x10s and R-30 fiberglass or cellulose, the Maine Model Building Energy Code calls for at least an additional R-8. An inch and one-half of poly-isocyanurate insulation will provide this, as shown in **Figure 38**. With lower R-value rigid insulation, such as extruded polystyrene, you will need an additional two inches to achieve an R-38.

To achieve a true R-38 or higher in an insulated sloped ceiling without compressing R-38 batt insulation (and thereby reducing its R-value), you will need to use a deeper rafter.

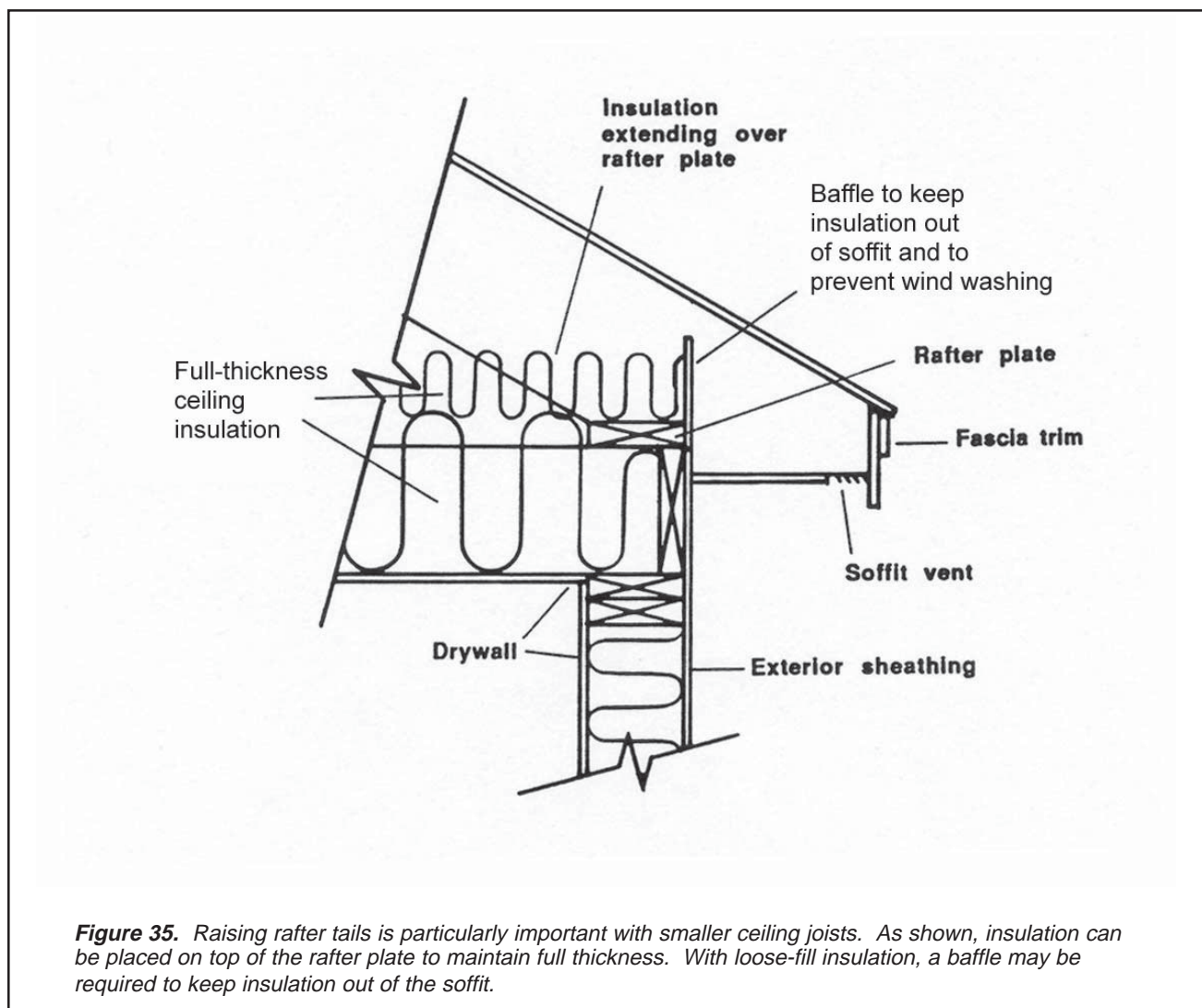

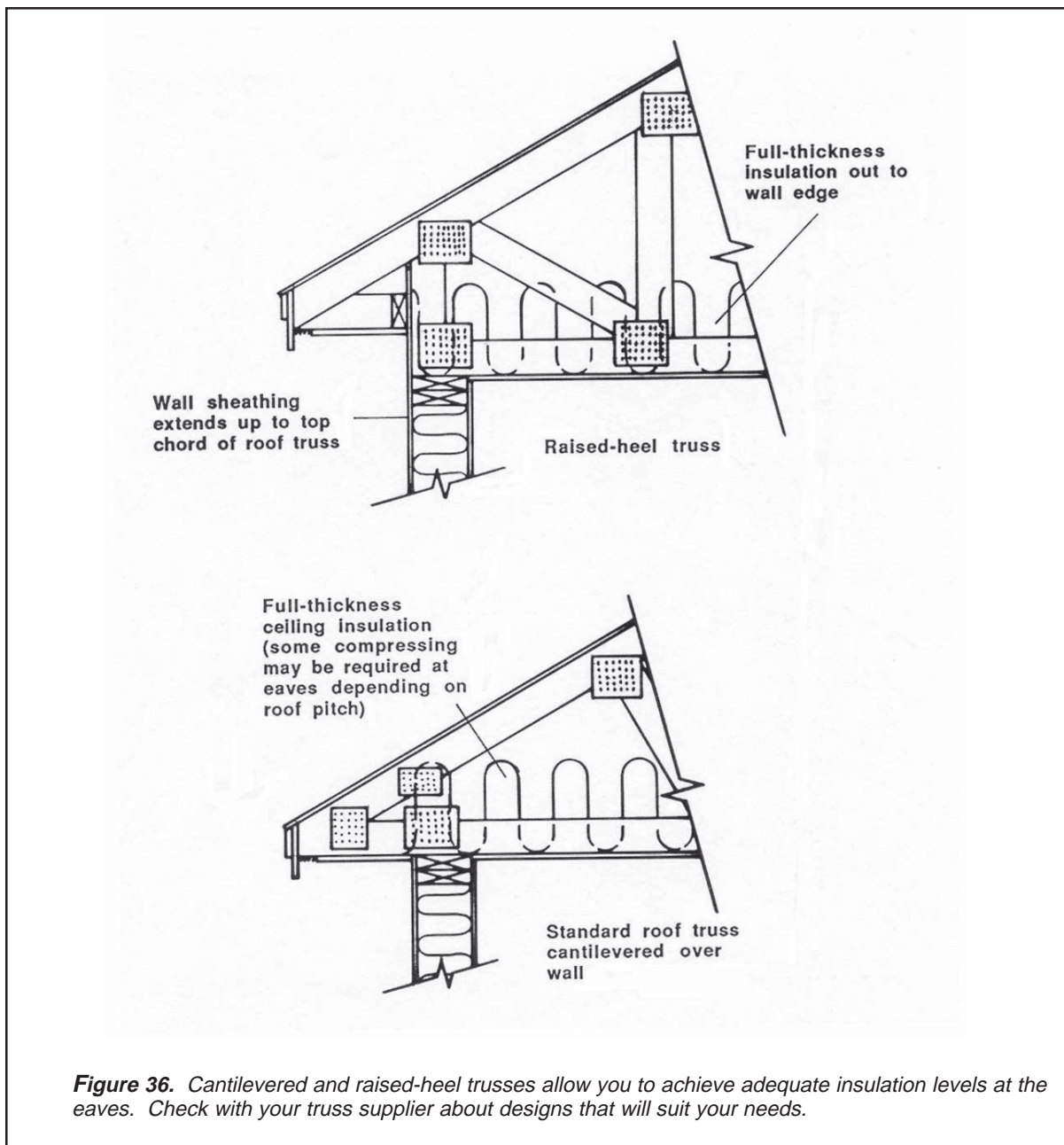

Figure 36. Cantilevered and raised-heel trusses allow you to achieve adequate insulation levels at the eaves. Check with your truss supplier about designs that will suit your needs.

Some contractors are using laminated wood **I-Joists**. These are available up to 16" deep and in lengths up to 28 feet. Because of their construction, they are far stronger than solid wood rafters, and they are much less likely to warp or twist. While their primary use is as floor joists, some builders of very well insulated homes use them for rafters as well. A detail using 14" I-joists as rafters with full-thickness R-38 insulation is shown in **Figure 39**. This method provides a full 2" air channel above the insulation as shown in the cross-section detail. If using this type of product, follow the manufacturer's recommen-

dations for installation, blocking, site storage and handling. While very strong when loaded on edge, I-joists are very weak when flat. Moving a long I-joist improperly could cause it to break.

Another alternative that allows you to use full-thickness R-38 batt insulation is to install raised-heel scissor trusses, as shown in **Figure 40**. While the ceiling pitch will generally be shallower than the roof pitch with this system, most homeowners find it satisfactory. Check with your truss manufacturer for scissor truss options.

The best strategy for effective ventilation is

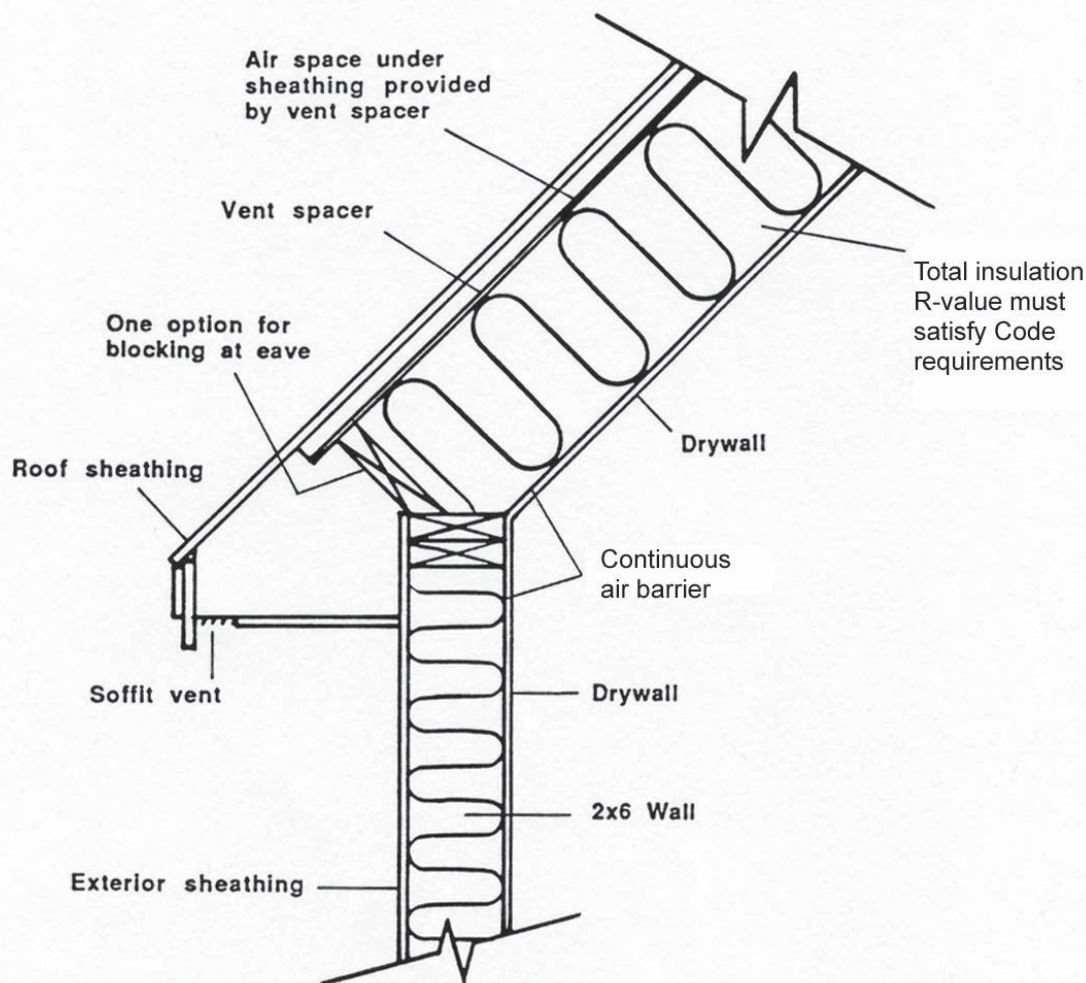

Figure 37. With cathedral ceilings, it can be challenging to comply with the Code. Before you start building, make sure your ceiling/roof design complies.

to provide continuous soffit and ridge vents. Soffit vents are generally built by providing two separate soffit boards with a 2" gap, spanned either with screening or a specialized metal soffit vent, as shown in **Figure 35**.

The general rule for roof ventilation is to provide one square foot of combined inlet and outlet vent area for every 300 ft² of sloped or flat insulated area. Refer to the complete venti-

lation discussion on pages 28 to 30 for more information on venting and calculating the required vent areas. Gable-end vents, though not as effective as a continuous ridge vent/soffit vent combination, are a viable alternative. If using a ridge vent, buy one of the commercially available products that effectively blocks rain, snow and insects.

The most difficult roof ventilation details are

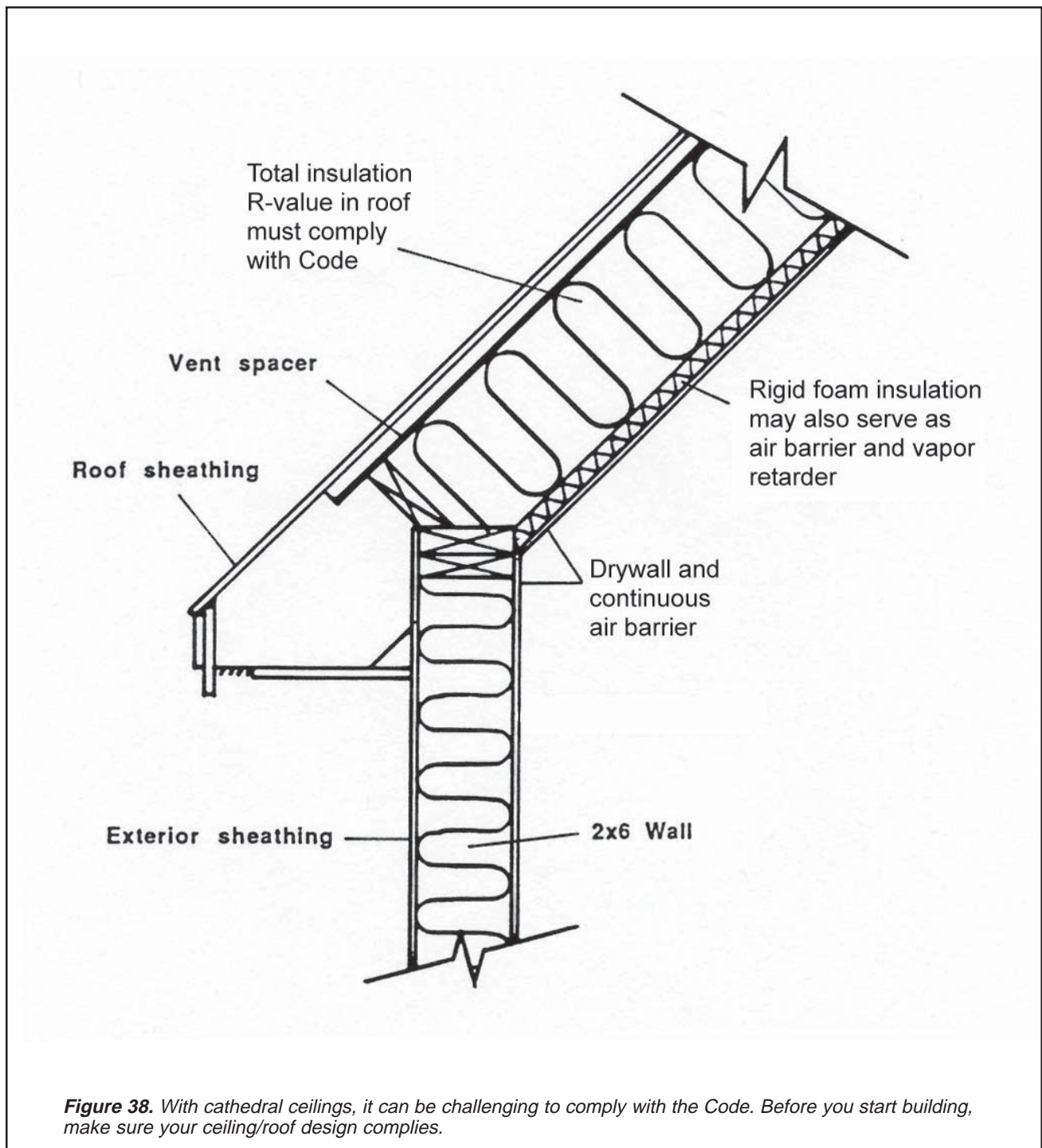

those around roof windows and at roof valleys and hips. To ventilate the rafter bays around roof windows, the best option is to drill 1" holes near the upper edge of the rafters, both above and below the roof windows, as shown in **Figure 41**. Though not as effective as a full air space at the top of the rafter cavity, these holes will allow some lateral air flow into adjacent rafter cavities. Unfortunately, most vent spacers are designed to

allow air to flow primarily upward along the roof sheathing. Look for vent spacers that provide lateral as well as vertical air flow.

At rafter hips and valleys, the best option is to use hip and valley rafters that do not extend all the way up to the tops of the other rafters. By leaving a one-inch gap at the top of these rafters, as shown in **Figure 42**, air will be able to flow into adjacent rafter cavities, making its

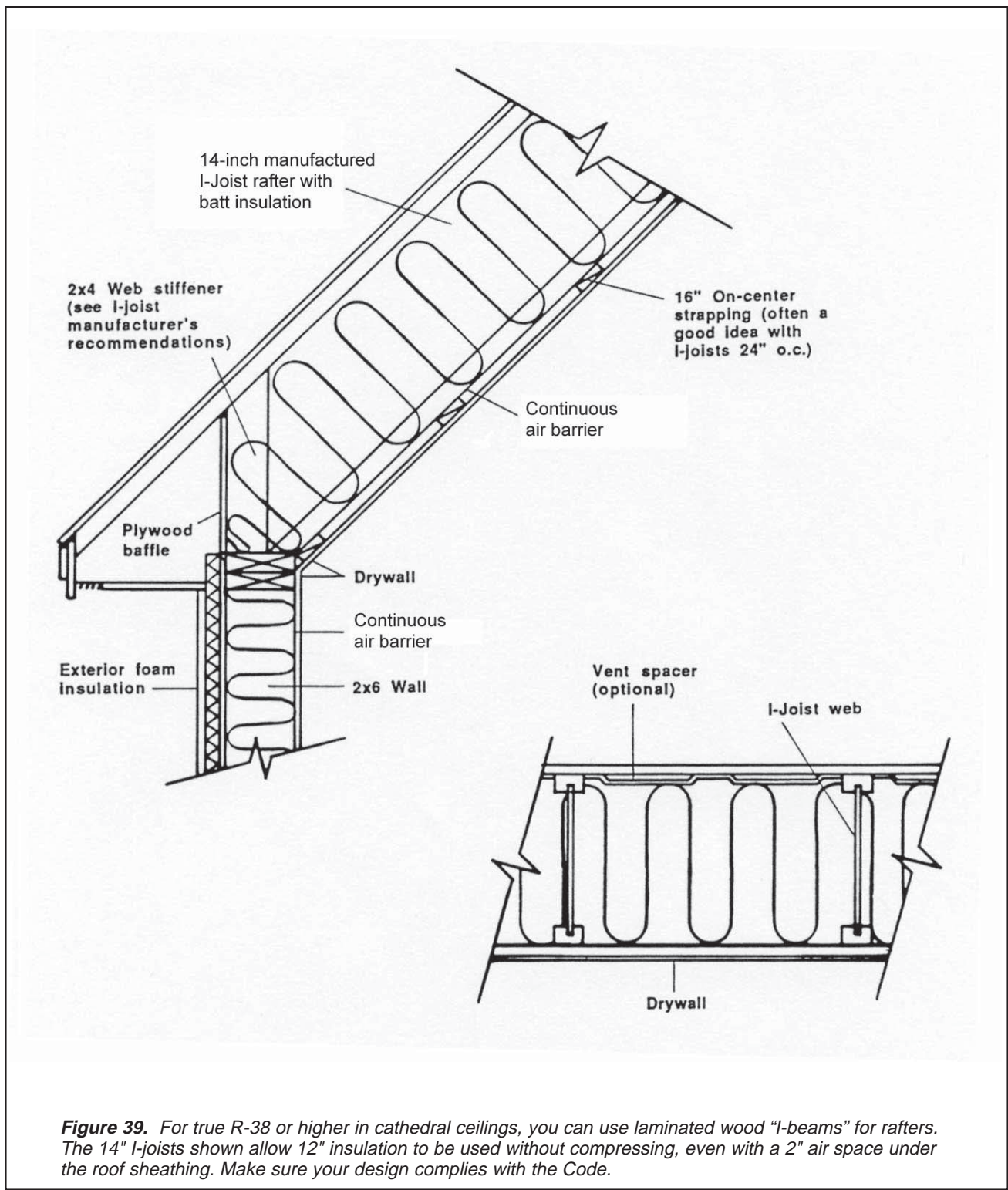
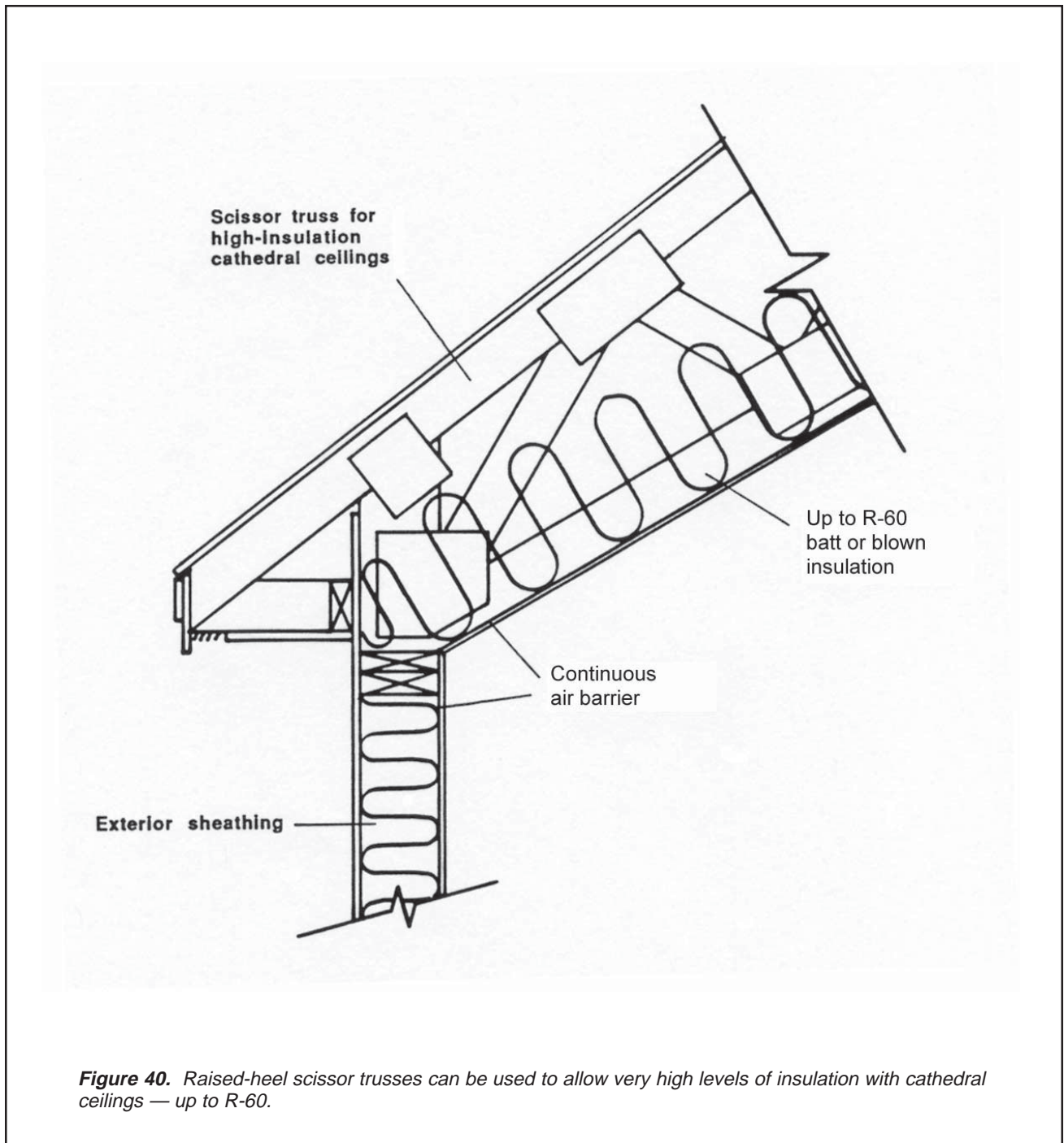

Figure 39. For true R-38 or higher in cathedral ceilings, you can use laminated wood "I-beams" for rafters. The 14" I-joists shown allow 12" insulation to be used without compressing, even with a 2" air space under the roof sheathing. Make sure your design complies with the Code.

way up to the ridge vent area. To achieve this, hip or valley rafters can be constructed so that their bottom edges are flush with the bottom edges of the rafters abutting them. Because the abutting rafters are cut at an angle, a space will be left at the top of the hip or valley rafters.

Because many building scientists feel that roof ventilation is not always necessary, many insulation contractors are installing dense-packed cellulose insulation into roof/ceiling cavities, leaving no space for ventilation (see page 30 for more details). This practice is



apparently working well, resulting in a uniform R-value and no long-term moisture problems. In addition, the cellulose insulation in a dense-packed state acts as a good air barrier. If this method is used, it is important to control relative humidity within the house during the winter to a level of 35 percent or less.

5. Structural Insulated Panel Systems

Structural Insulated Panel Systems (SIPS) have emerged as a viable alternative to the standard practice of framing and insulating walls and roofs. When properly installed, these one-component panels offer both high insulation values and low air leakage.

SIPS were first used in residential construc-

tion for enclosing and insulating **timber frame** houses. In this application, panels are installed on the outside of the frame, fully enclosing it with the insulated wall or roof system (see **Figure 43**). SIPS for timber frame buildings generally have an inner skin of drywall, a core of rigid expanded polystyrene (EPS) or polyurethane foam, and an outer skin of plywood or oriented strand board (OSB). When secured to the frame, the panels provide a nearly finished inner wall surface and exterior sheathing, ready for siding or roofing. Varying thicknesses are available, providing R-values from R-15 to R-40.

More recently, SIPS have been used in “frameless” houses, where the panels provide the necessary structural envelope, as well as the insulation system. In this application, the panels are often called structural panels. Plywood or OSB is used as both the inner and outer skin of the panels. Structural **splines** are used to join the panels, with wall and roof sections held together by floor joists, rafters and other structural

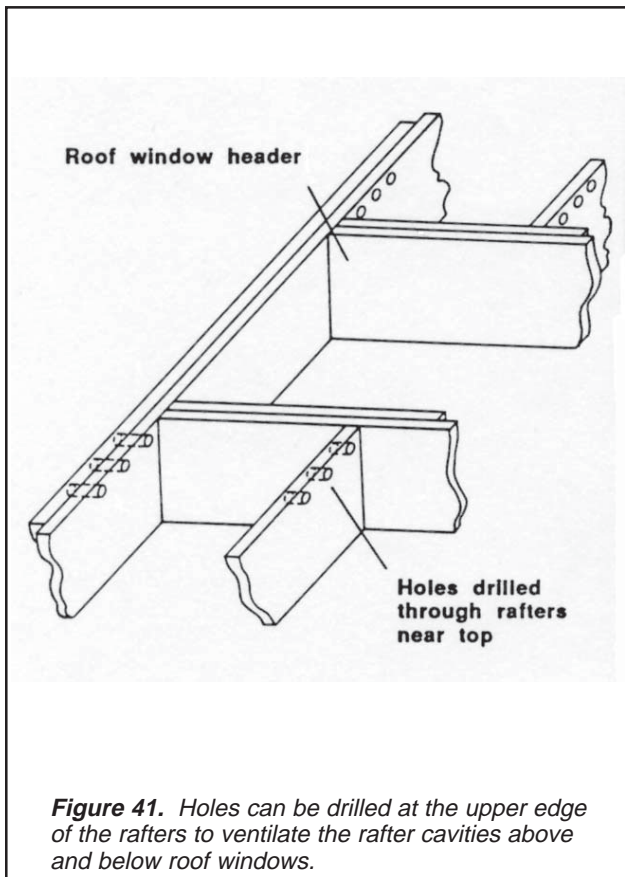

Figure 41. Holes can be drilled at the upper edge of the rafters to ventilate the rafter cavities above and below roof windows.

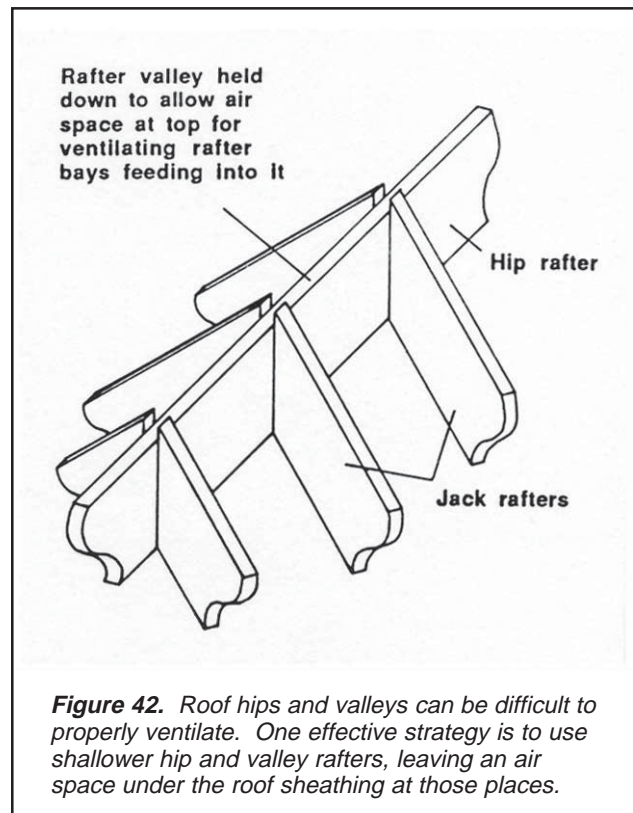

Figure 42. Roof hips and valleys can be difficult to properly ventilate. One effective strategy is to use shallower hip and valley rafters, leaving an air space under the roof sheathing at those places.

components, as shown in **Figure 44**. Because the inner skin of structural panels is plywood or OSB, a layer of drywall must be installed to comply with fire codes. Because of the large open spans achievable, however, drywall application can generally be done before interior partition walls are built, greatly simplifying the drywall installation and finishing.

With structural insulated panels, manufacturers generally provide either ready-to-erect kits or fully erected shells, ready for finishing. Each manufacturer has its own specific installation guidelines and details for joining and sealing panels, which must be followed. Sealing between the panels with foam sealant is particularly important for the prevention of heat loss and moisture migration through the wall or roof.

As mentioned above, both EPS and polyurethane-core panels are available. Each has its advantages and disadvantages. Check with manufacturers for specifications.

Building with SIPS can keep labor costs down and enable houses to be erected and closed in very quickly. Greater energy efficiency is often achieved with SIPS houses

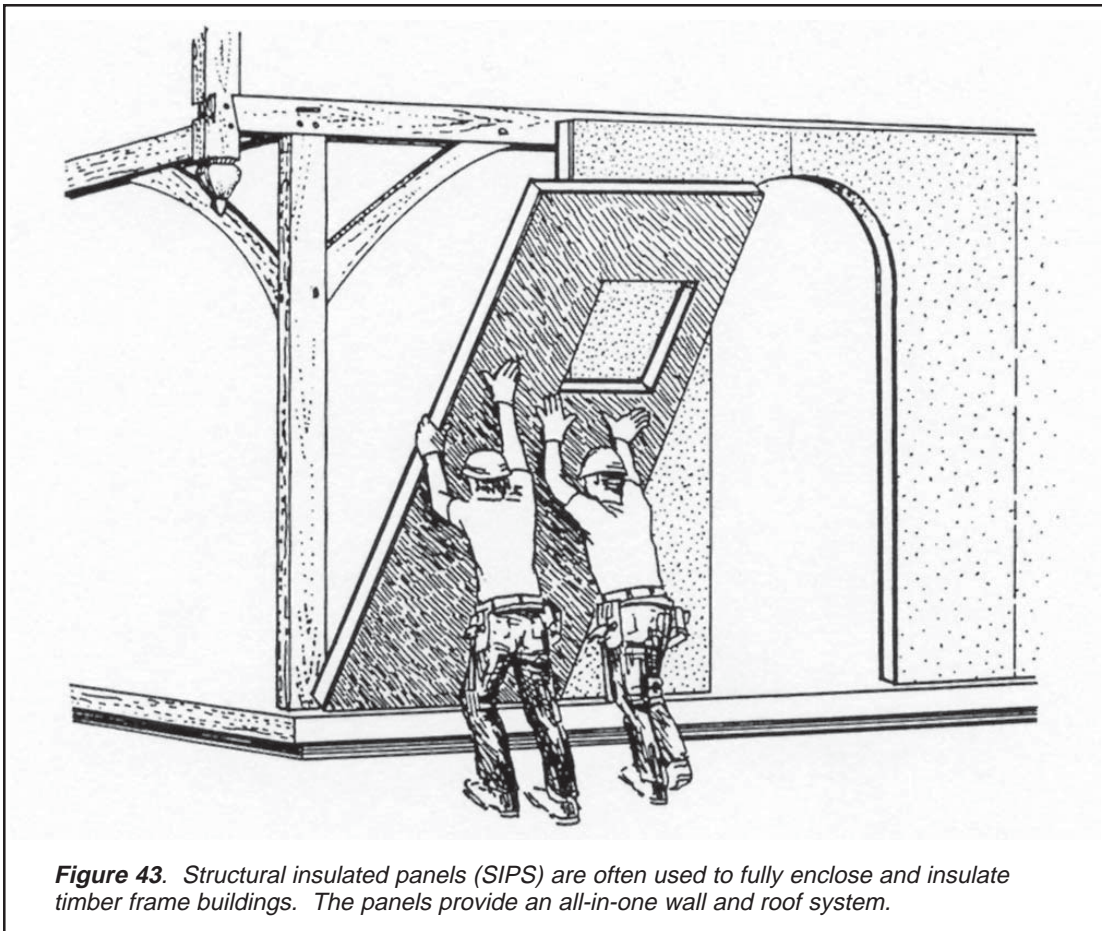

compared to conventional homes with comparable R-values. This results from the lack of bypass heat loss through framing members and the increased air tightness that can be achieved with SIPs.

6. Installing Windows and Doors

As mentioned previously in this manual, energy-efficient windows and doors provide one of the best opportunities for complying with the Maine Model Energy Building Code. Windows are available with overall insulating values up to R-4.0, and exterior doors are available that insulate to R-6. Minimizing heat loss through windows and doors is not solely a question of which model you buy; it also depends on the quality of installation. Air leakage around windows and doors often accounts for more heat loss than the heat being transmitted through the surface of the units.

Always follow window and door manufacturer's instructions when installing the units.

Specific details may vary from one manufacturer to another and from one style to another. The key to tight installation of windows and doors is sealing between the jamb and the rough opening. While fiberglass insulation can be used here, it does *not* provide an air seal. Foam sealant provides the best seal, and it provides a good R-value. Choose a low-expanding foam sealant; they are not as likely to bulge window or door jambs as the high-expanding foam.

When sizing the rough opening and installing the window or door, make sure there is enough space between the jamb and rough opening to insert the nozzle for the foam sealant ($\frac{3}{8}$ " to $\frac{1}{2}$ "). Apply a continuous bead of foam sealant in the gap, working from the outside to the inside, welding the jamb to the jack studs, header and sill (see **Figure 45**). Apply the foam in several beads, allowing the foam to cure between applications (usually a minimum of one-half hour).

Operable windows and doors should always

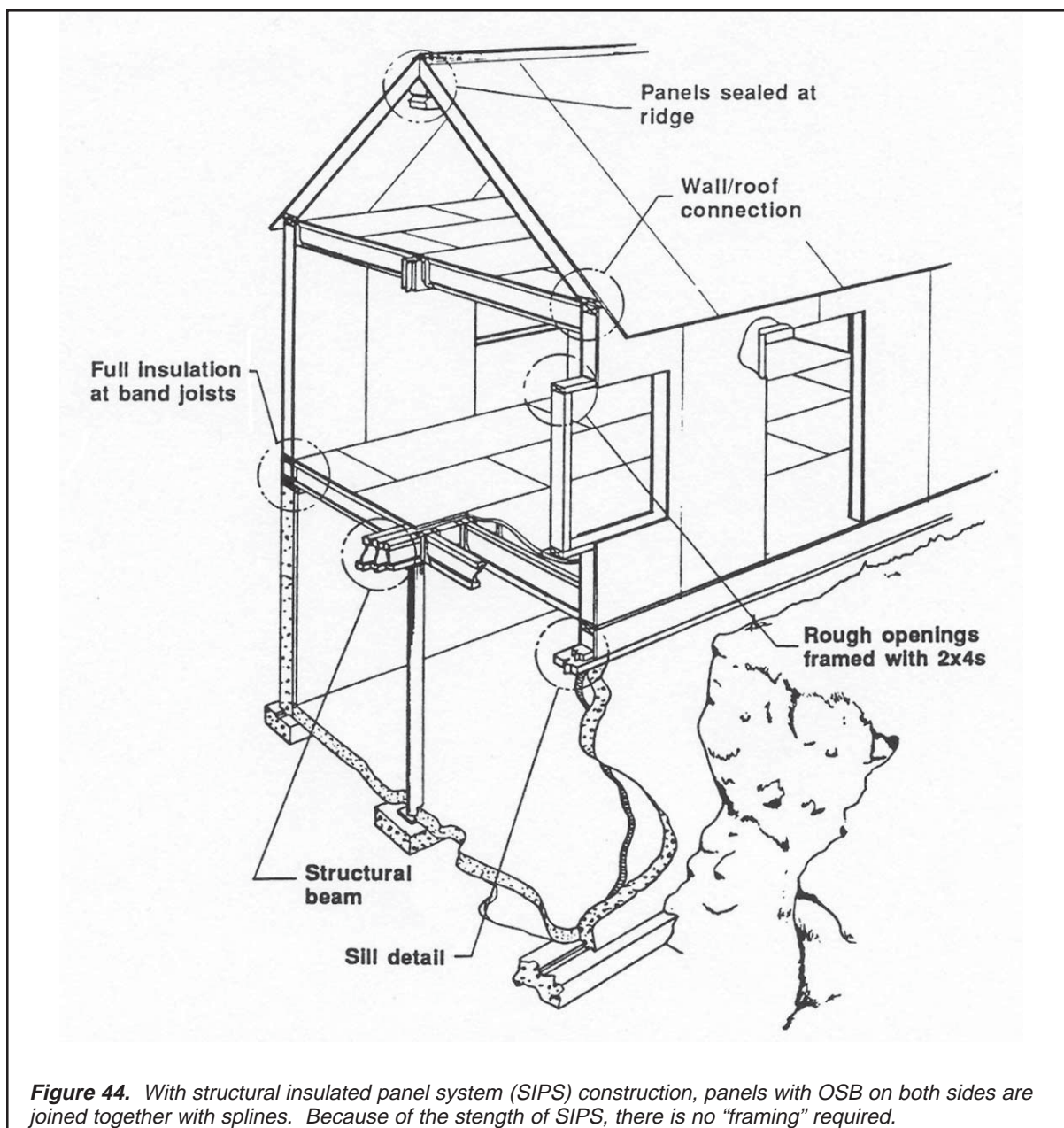

Figure 44. With structural insulated panel system (SIPS) construction, panels with OSB on both sides are joined together with splines. Because of the strength of SIPS, there is no “framing” required.

be purchased pre-hung to achieve the greatest tightness. Always flash windows properly with house wrap or other appropriate materials. It is likely that during the service life of a window or door unit that some water leakage will occur. Flashing units properly on all sides so that water drains away will prevent any water damage.

As an additional measure to ensure tightness, interior window and door casings can be caulked in place. Apply a bead of high quality caulk on the interior jamb edge and on the drywall where the casing will sit. However, if the window or door jamb has been properly sealed elsewhere, caulking is not required.

7. Other Measures to Reduce Air Leakage

Keeping natural air leakage to a minimum in new construction requires careful attention to details throughout the construction process. Framing should be done carefully to ensure tight fits. Use high quality air sealing products as described in this guide. A number of particularly troublesome air leak locations and the recommended practices for sealing them are shown in **Figures 47 through 52**. More comprehensive references on how to seal houses are included in the **Appendix E**.

8. Commissioning

The commissioning process has been a routine part of commercial construction for years. It is a good idea to make it a part of residential construction today.

Commissioning is the process of ensuring—by testing—that the building and all its systems (heating, venting, cooling, electrical, etc.) are functioning as intended. The commissioning can be done by the designer, the contractor, or another competent person. At a minimum, the commissioning process should include:

- Testing the building envelope for leakage;
- Testing the ductwork for leakage;
- Testing air pressures in the building under all operating conditions;
- Testing to ensure that all combustion appliances vent properly under all operating conditions;
- Testing for carbon monoxide from all combustion appliances; and
- Testing and confirming proper operation of all heating, ventilating and air conditioning equipment.

This important process means healthier and higher quality houses, enhances the reputation of the builder, and ensures that the home buyer is getting what they have paid for.

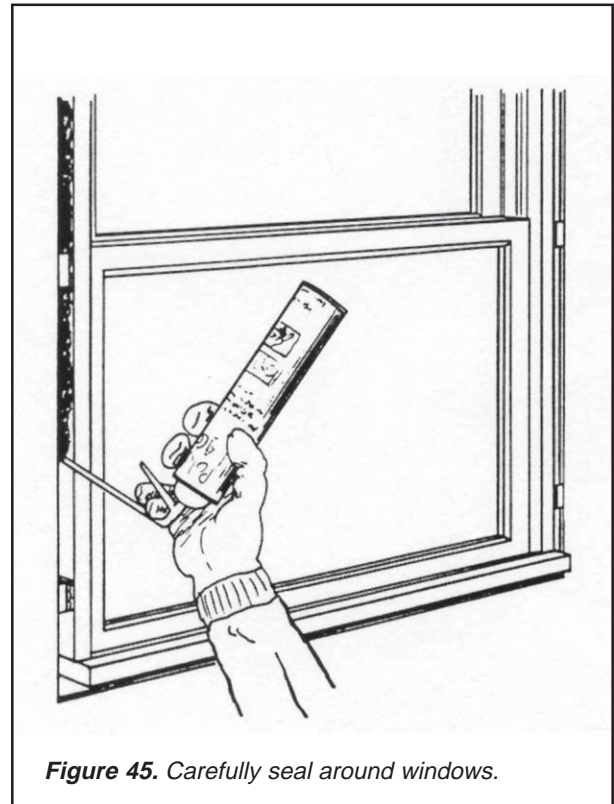
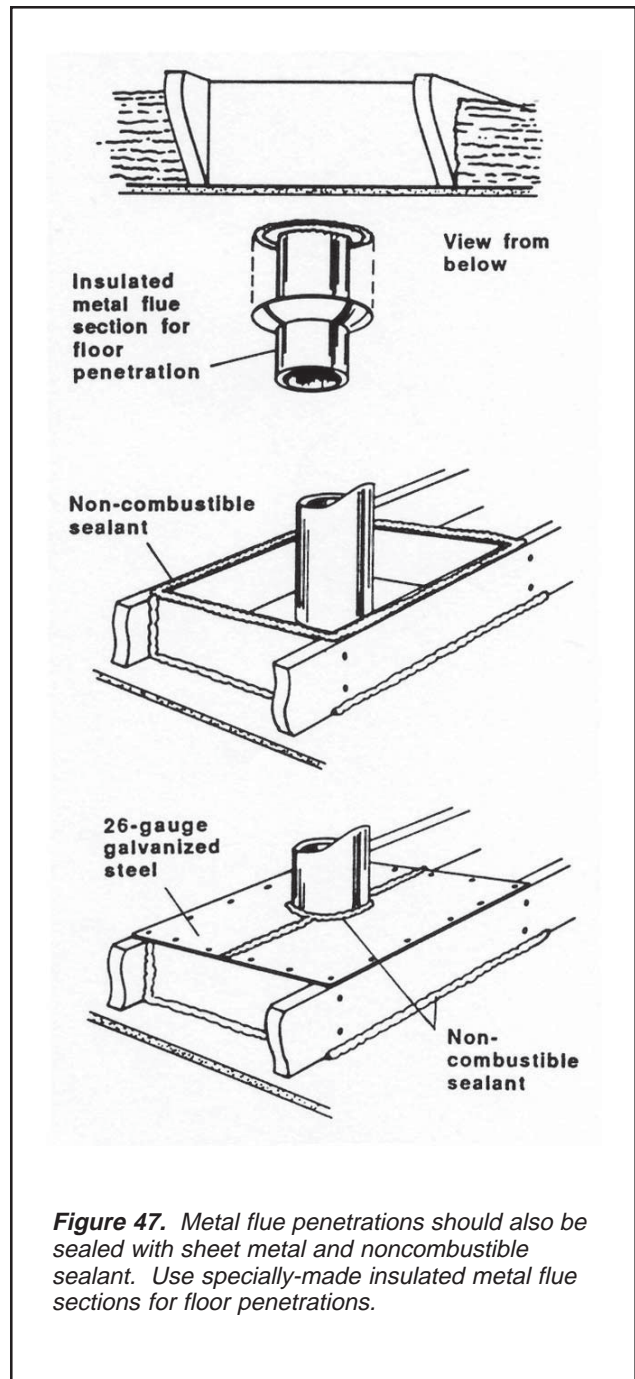
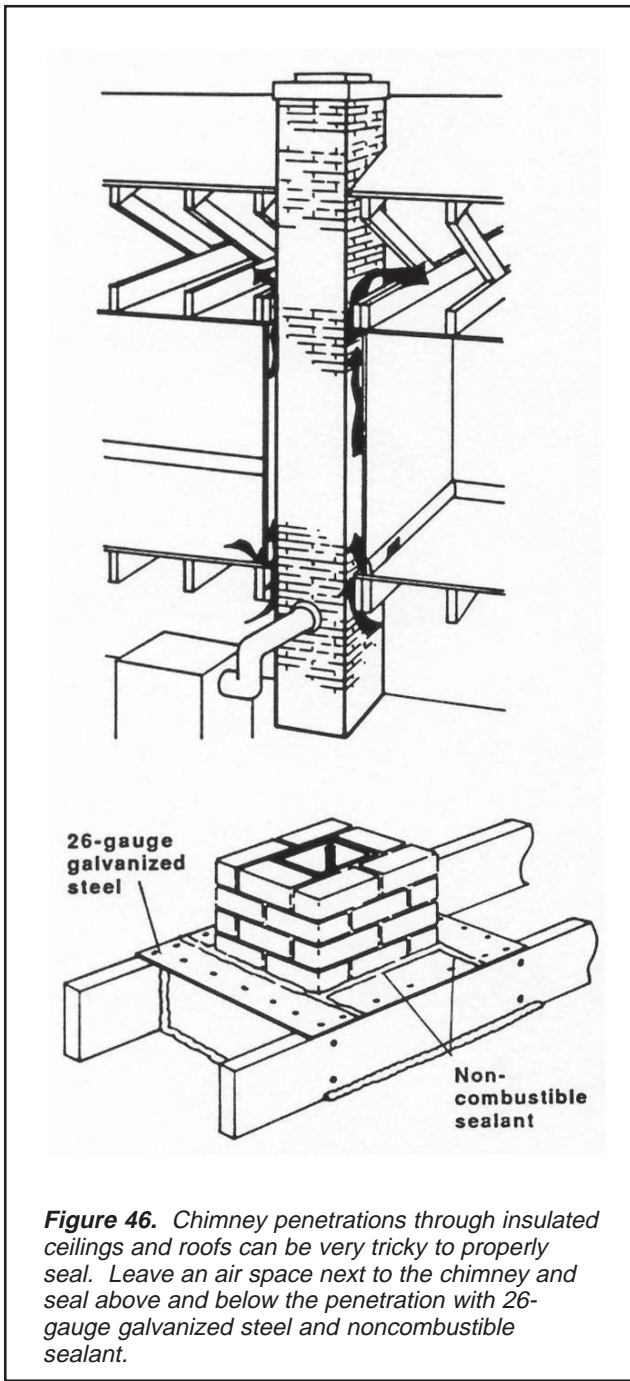
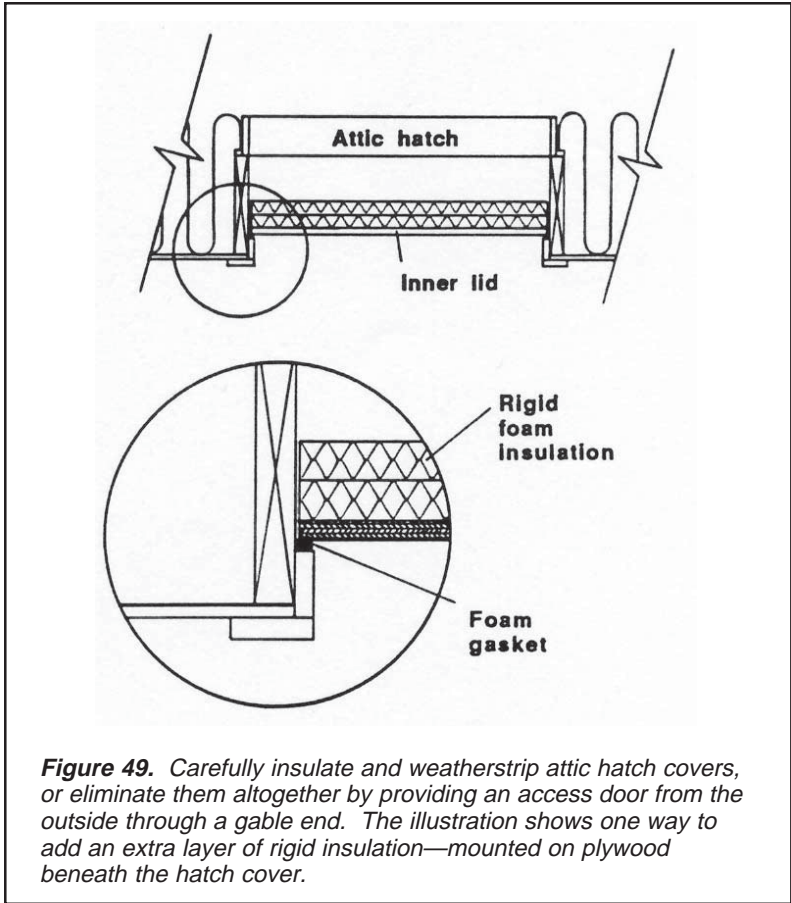
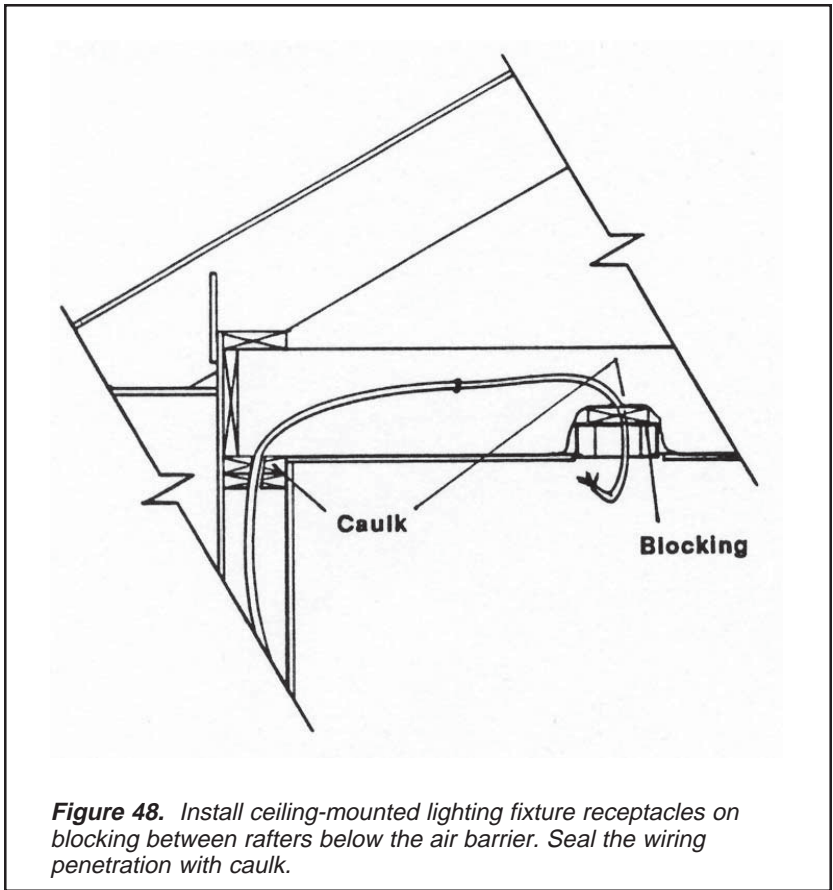
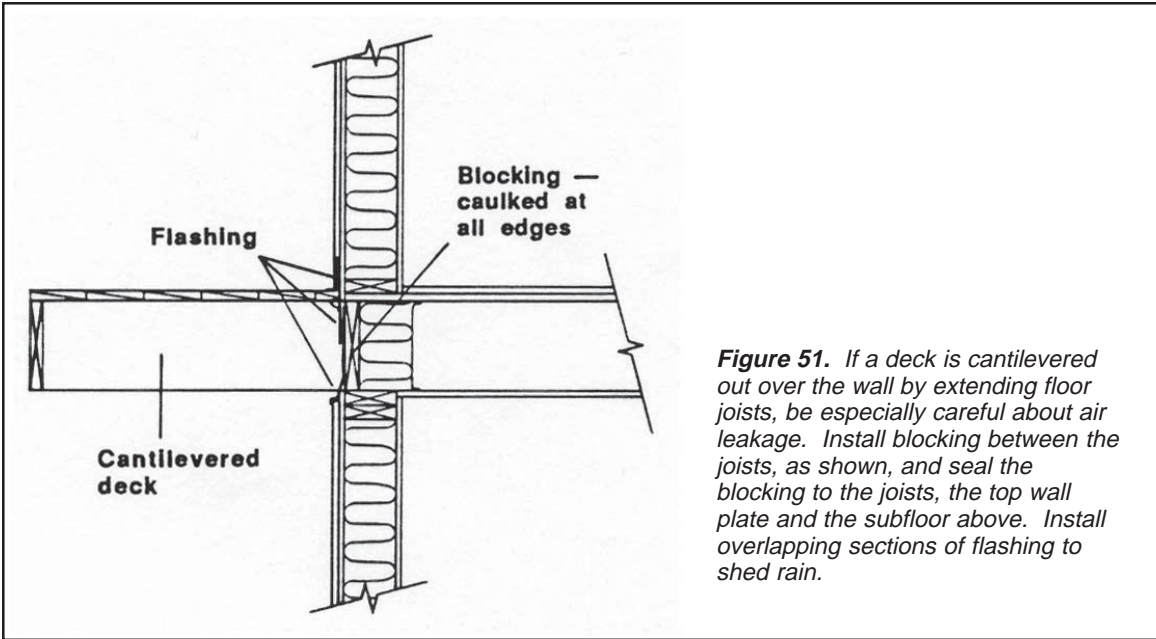
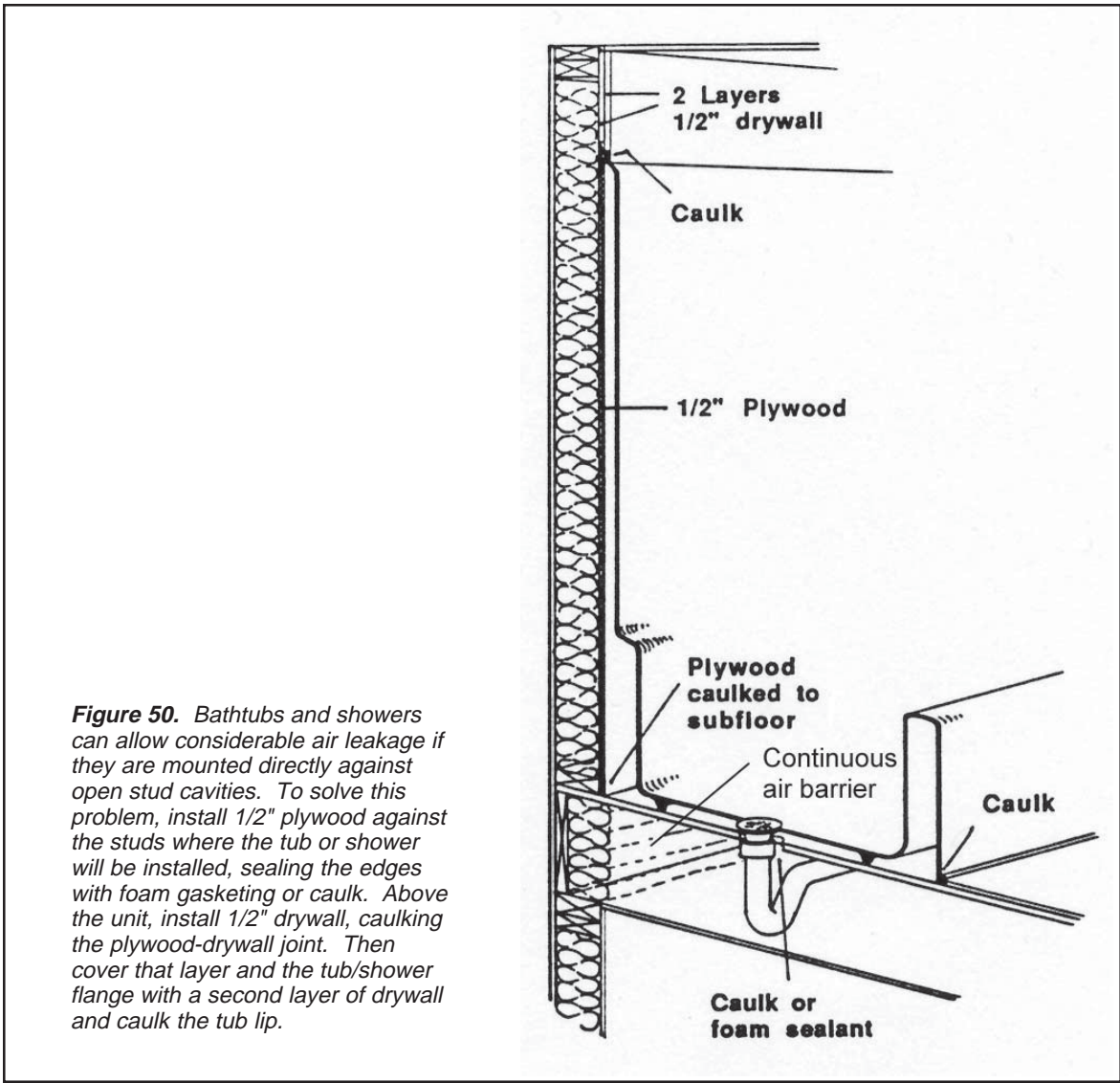

Figure 45. Carefully seal around windows.







Appendix A

Heat Loss Calculations

Determining a building's heating load is important for a number of reasons, including sizing heating systems and calculating annual heating loads (if you want to determine how much oil, gas or wood is required for the heating season, for example). To calculate heat loss, you should start by measuring the areas of all the different components of the building envelope and calculating the **heat loss coefficient (U-factor)** of each of those areas. Organize the information in a worksheet such as **Worksheet A** on page 74. If there are several types of walls with different R-values, you will need one line for each type. If several *different* building components have the same total R-values (for example, the floor over an unheated crawl space and an insulated cathedral ceiling), you can combine these areas onto one line on the worksheet.

For Worksheet A, calculate the U-factor for an assembly part of the building by adding up the R-values of each component. Refer to a chart of R-values of building materials, such as the one shown in Appendix B (more complete R-value listings are available in many publications). In walls and ceilings where there are studs, joists or rafters along with the

insulation, the average R-value should take both the insulation area and the wood framing area into account. For stud walls with the studs 16" on center (o.c.), the studs comprise 20% of the wall area and the cavities 80%. For a stud wall 24" o.c., the studs comprise 15%, and the cavities 85%. For rafters and joists, assume that 16" o.c. framing comprises 15% and the cavities 85%. For a 24" o.c. floor, ceiling or roof, the framing comprises 10% and the cavities 90%.

The R-values of a sample 2x6 wall system with exterior rigid foam insulation are added up in **Table A** below. Two columns are used to account for the lower insulation value through the studs. Component R-values are listed and then added together. These are, in turn, multiplied by the stud ratio multipliers and the two results are added, as shown in the table. The overall U-factor is found by dividing the R-value into one ($U=1/R$).

This total corrected U-factor is entered onto Worksheet A and multiplied by the measured area for that wall component. Complete the worksheet by carrying out similar calculations for the rest of the building assemblies. With windows and doors, you may be able to use U-factors supplied directly by manufacturers.

Table A		
<u>Wall Component</u>	<u>Cavity R-value</u>	<u>R-value through Studs</u>
Inside air film	.68	.65
1/2" Drywall	.45	.45
Fiberglass batt insulation	19.00	0.00
2x6 studs	0.00	6.90
1/2" plywood sheathing	.50	.50
1" Extruded polystyrene	5.00	5.00
1/2" bevel siding	.81	.81
Outside air film	<u>.17</u>	<u>.17</u>
Total R-Value	26.61	14.48
Stud Ratio Multiplier	<u>x .8</u>	<u>x .2</u>
Total Corrected R-value	21.288	+ 2.896
		= 24.184

Foundations can be a difficult part of heat loss calculations. Accurate foundation heat loss calculations depend on many variables, including soil type. For a quick heat loss calculation for a full basement, you can divide the foundation into above-grade and below-grade areas. For the above-grade part, simply add up the total R-value, as described previously. For the below grade portion, add up the component R-values and multiply the total R-value by 1.5 to take into account the reduced heat loss through the ground. Enter each on Worksheet A, below. This will provide a *conservative* estimate of total foundation heat loss, and it should suffice for most heating load determinations.

With slab-on-grade construction, a different calculation procedure should be used. If the slab is insulated according to the Maine Model Energy Building Code (insulation covering the perimeter of the slab and extending horizontally under the slab), the R-value you should use in the heat loss calculations depends on the thickness of the insulation and the area of the slab. With extruded polystyrene insulation, you can use the graph below to determine the "equivalent" R-value of the entire slab.

By adding up all the heat loss ($U \times A$) values on Worksheet A, you obtain the total surface heat loss through the building envelope in Btu/°F hr. You still need to determine the heat loss caused by air leakage. To make this calculation, you need to calculate the total conditioned, above-grade volume of the house, and then assign a number for air tightness in air changes per hour (ACH). The air tightness can be measured with a blower door, or it can be estimated. By building to Maine's Model Energy Building Code, the air

exchange rate will be between 0.4 and 0.1, with an average figure of 0.3 ACH. Calculate the air exchanged every hour by multiplying the total volume by the ACH estimate. Fill in Worksheet A with this information.

Once all the information is put into Worksheet A, the total heat loss numbers ($U \times A$) can be added to arrive at the building's total **heat loss coefficient** in Btu/°F hr. (see number 1 on the bottom of Worksheet A on page 74). With that number, you can easily compute either hourly heating load for sizing heating systems, or total heating requirements on a yearly basis. To compute hourly heating load using Worksheet A, plug in values for the heating outdoor design temperature (see **Table D**) and inside temperature, and multiply the resulting temperature differences by the building's heat loss coefficient (see number 2 on the bottom of Worksheet A on page 74). This yields the amount of heat output required from the heating system to maintain the desired inside temperature (70°F) when the outside temperature is the heating design temperature.

To calculate heating requirements for a full year, we need to use **heating degree day** information (Table D). Degree-day numbers are used by fuel companies to determine when they need to make deliveries. Each day, the high and low temperature is recorded and averaged $[(\text{high} + \text{low}) \div 2]$. If that average is below 65°F, the difference is the number of degree days for that day. Yearly degree days are calculated by adding these numbers for the year. In Maine, annual heating degree-days range from 7,000 to 10,000. Values for several cities are shown in **Table B**. Use Worksheet A to compute the annual heating load (see number 3 on the bottom of Worksheet A on page 74).

Table B
Annual Heating Degree-Days

Augusta	7826
Bangor	8220
Caribou	9770
Eastport	8246
Lewiston	7690
Millinocket	8533
Portland	7570

Table C
Heat Content of Common Fuels

Fuel Source	Btu content
Heating oil	139,000 Btu/gallon
Natural gas	1030 Btu/cubic foot
LP gas	91,600 Btu/gallon
Mixed hardwood	24 million Btu/cord
Electricity	3412 Btu/kWh

There is still one more step in determining annual fuel use: converting Btus to quantity of fuel. In Worksheet A, plug in values for the heat content of your fuel (Btu/gal for oil; Btu/ccf for natural gas, Btu/cord for wood, etc.) and the efficiency at which it is burned. Refer to **Table C** for the heat content of common fuels. Heating system efficiencies (Annual Fuel Utilization Efficiency) can be obtained from equipment manufacturers or dealers (see number 4 on the bottom of Worksheet A on the next page). Note that this value is an *estimate* only, annual heating requirement and fuel use might vary significantly from this value.

Table D

***Heating Outdoor
Design Temperature (97.5%)***

Augusta	-3
Bangor	-6
Caribou	-13
Eastport	-4
Lewiston	-2
Millinocket	-9
Portland	-1
Waterville	-4

WORKSHEET A Heating Load Calculations

Assumptions (fill in):

Air changes per hour (ACH) _____
 Heating outdoor design temperature (97.5%, Table D) _____
 Inside design temperature _____
 ΔT (inside design temp. – heating outdoor design temp.) _____
 Average annual heating degree-days (HDD, Table B) _____
 HDD Correction factor (C_f), (Use 0.62 for 7000 HDD, 0.69 for 8000 HDD, and 0.67 for 9000 HDD) _____
 Heating system efficiency _____
 Fuel type and heat content (Table C) _____

Building Envelope Surface Heat Loss:

Building Assembly Part	U-Factor (Btu/ft ² , °F hr)	x	Net Area (ft ²)	=	Heat Loss Coefficient (Btu/°F, hr)
Total					

Air Leakage Heat Loss:

Air changes per hour (ACH)	x	House Volume (ft ³)	x	.018 (Btu/ft ³ , °F hr)	=	Heat loss coefficient (Btu/°F, hr)

1. Total Heat Loss Coefficient (Btu/°F hr) _____
 (Total surface loss plus air leakage)
2. Heating Load at Heating Design Temperature (Btu/hr) _____
 (Total heat loss coefficient x ΔT)
3. Total Annual Heat Requirement (Btu/yr) _____ [rough estimate]
 (Total heat loss coefficient x 24 x HDD x C_f)
4. Total Fuel Requirement (gallons oil/yr, gallons lp gas/yr, ccf gas/yr, or cords wood/yr) _____
 (Total annual heat needs ÷ (heating system efficiency x Btu content of fuel/unit)) [rough estimate]

Comparing Heating Fuel Costs

Heating System Efficiency	\$11.70	\$14.63	\$17.55	\$20.48	\$23.40	\$26.33	\$29.25	\$32.18	\$35.10	\$38.03	\$40.95	\$43.88	\$46.80	Heating Equivalent \$/MMBTU
100%	\$0.04	\$0.05	\$0.06	\$0.07	\$0.08	\$0.09	\$0.10	\$0.11	\$0.12	\$0.13	\$0.14	\$0.15	\$0.16	Electric Resistance, cents/kWh (3,413 Btu/kWh)
200%	\$0.08	\$0.10	\$0.12	\$0.14	\$0.16	\$0.18	\$0.20	\$0.22	\$0.24	\$0.26	\$0.28	\$0.30	\$0.32	Heat Pump (air source), cents/kWh (3,413 Btu/kWh)
350%	\$0.14	\$0.175	\$0.21	\$0.246	\$0.28	\$0.316	\$0.35	\$0.386	\$0.42	\$0.456	\$0.49	\$0.526	\$0.56	Heat Pump (earth source), cents/kWh (3,413 Btu/kWh)
92%	\$1.08	\$1.34	\$1.62	\$1.88	\$2.16	\$2.42	\$2.70	\$2.96	\$3.24	\$3.50	\$3.78	\$4.04	\$4.30	Natural Gas \$/Therm High Efficiency (100,000 Btu/Therm)
80%	\$0.94	\$1.17	\$1.41	\$1.64	\$1.88	\$2.11	\$2.35	\$2.58	\$2.82	\$3.05	\$3.29	\$3.52	\$3.75	Natural Gas \$/Therm Low Efficiency (100,000 Btu/Therm)
80%	\$1.26	\$1.58	\$1.90	\$2.22	\$2.54	\$2.86	\$3.15	\$3.47	\$3.79	\$4.11	\$4.43	\$4.75	\$5.05	#1 Fuel Oil (Kerosene), \$/Gal. (135,000 Btu/Gal.)
80%	\$1.29	\$1.63	\$1.95	\$2.27	\$2.61	\$2.93	\$3.25	\$3.59	\$3.90	\$4.24	\$4.56	\$4.88	\$5.22	#2 Fuel Oil, \$/Gal. (139,000 Btu/Gal.)
80%	\$0.83	\$1.06	\$1.27	\$1.48	\$1.68	\$1.89	\$2.10	\$2.31	\$2.51	\$2.72	\$2.93	\$3.14	\$3.37	Propane, \$/Gal. (92,000 Btu/Gal.)
92%	\$1.00	\$1.24	\$1.48	\$1.74	\$1.98	\$2.24	\$2.48	\$2.74	\$2.98	\$3.24	\$3.48	\$3.74	\$3.96	Propane, \$/Gal. High Efficiency (92,000 Btu/Gal.)
75%	\$0.56	\$0.70	\$0.86	\$1.00	\$1.14	\$1.28	\$1.42	\$1.56	\$1.70	\$1.84	\$1.98	\$2.12	\$2.28	Methanol, \$/Gal. (64,700 Btu/Gal.)
75%	\$0.60	\$0.74	\$0.88	\$1.04	\$1.18	\$1.32	\$1.46	\$1.62	\$1.76	\$1.90	\$2.06	\$2.20	\$2.36	Ethyl Alcohol 160 Proof, \$/Gal. (67,200 Btu/Gal.)
75%	\$0.66	\$0.84	\$1.00	\$1.16	\$1.34	\$1.50	\$1.66	\$1.84	\$2.00	\$2.16	\$2.34	\$2.50	\$2.66	Ethyl Alcohol 180 Proof, \$/Gal. (75,600 Btu/Gal.)
75%	\$0.74	\$0.92	\$1.10	\$1.30	\$1.48	\$1.66	\$1.86	\$2.04	\$2.22	\$2.40	\$2.60	\$2.78	\$2.96	Ethyl Alcohol 200 Proof, \$/Gal. (84,000 Btu/Gal.)
75%	\$1.06	\$1.32	\$1.60	\$1.86	\$2.12	\$2.40	\$2.66	\$2.92	\$3.18	\$3.46	\$3.72	\$4.00	\$4.24	Gasohol (90/10), \$/Gal. (120,900 Btu/Gal.)
75%	\$1.08	\$1.36	\$1.64	\$1.90	\$2.18	\$2.46	\$2.72	\$3.00	\$3.26	\$3.54	\$3.82	\$4.08	\$4.36	Gasoline Unleaded, \$/Gal. (124,000 Btu/Gal.)
70%	\$1.06	\$1.32	\$1.60	\$1.86	\$2.12	\$2.40	\$2.66	\$2.92	\$3.18	\$3.46	\$3.74	\$4.08	\$4.26	Vegetable Oil, \$/Gal. (130,000 Btu/Gal.)
65%	\$3.62	\$4.54	\$5.44	\$6.34	\$7.26	\$8.16	\$9.06	\$9.96	\$10.88	\$11.78	\$12.70	\$13.60	\$14.50	Shelled Corn, \$/Bushel (8,500 BTU/lb @ 15.5% moisture)
65%	\$3.98	\$4.98	\$5.96	\$6.96	\$7.96	\$8.94	\$9.94	\$10.94	\$11.92	\$12.92	\$13.92	\$14.92	\$15.90	HRS Wheat (Grain), \$/Bushel (8,700 Btu/lb @ 13.5% moisture)
65%	\$3.00	\$3.74	\$4.50	\$5.24	\$6.00	\$6.74	\$7.50	\$8.24	\$9.00	\$9.74	\$10.50	\$11.24	\$11.98	Barley (Grain), \$/Bushel (8,200 Btu/lb @ 12.5% moisture)
65%	\$114.26	\$142.84	\$171.40	\$199.96	\$228.54	\$257.10	\$285.68	\$314.24	\$342.80	\$371.38	\$399.94	\$428.50	\$457.06	Wheat and Barley Straw, \$/Ton (7,500 Btu/lb @ 8% moisture)
65%	\$157.25	\$196.46	\$235.77	\$270.08	\$314.34	\$353.65	\$392.96	\$432.28	\$471.54	\$510.85	\$550.11	\$589.42	\$628.73	Wood, \$/128 ft3 (standard cord) 6,200 Btu/lb @ 20% moisture
50%	\$120.92	\$151.12	\$181.36	\$211.60	\$241.80	\$272.04	\$302.28	\$332.52	\$362.72	\$392.96	\$423.16	\$453.40	\$483.64	Wood, \$/128 ft3 (standard cord) 6,200 Btu/lb @ 20% moisture
65%	\$100.54	\$125.70	\$150.84	\$175.98	\$201.12	\$226.26	\$251.40	\$276.54	\$301.68	\$326.80	\$351.94	\$377.08	\$402.22	Coal (Lignite), \$/Ton (6,600 Btu/lb @ 12% moisture)

Comparing Heating Fuel Costs

The cost of various sources of energy are expressed in different ways, making comparison difficult. The preceding chart will enable you to compare the cost of various heating fuels on the basis of their equivalent costs, as expressed in dollars per million BTU (\$/MMBTU) in the top row of the chart. To use the chart, read across the fuel price row until you come to the current cost per unit of a fuel you want to compare to another. Now move up that column to the top row to find the Heating Equivalent in \$/MMBTU. Now find the current price of the other fuel you are comparing with the first. Move up this column to the top row to find the second fuel's Heating Equivalent in \$/MMBTU. Now you can compare the Heating Equivalent in \$/MMBTU.

For example, you might want to know how the cost of heating with wood compares with the cost of heating with #2 fuel oil. If mixed hardwood is to be burned in a standard airtight stove at 50% efficiency and is available at \$211.60 per cord, the Heating Equivalent is \$20.48/MMBTU. If fuel oil is available at \$1.95 per gallon and burned in a new heating system at 80% efficiency, its Heating Equivalent is \$17.55/MMBTU. Therefore, at these prices, oil is cheaper than wood. Alternatively, you can use the chart to determine that \$211.60 per cord wood is the equivalent to \$2.27 per gallon #2 fuel oil.

If you are considering switching fuels, remember the cost of the heating equipment. If the difference between the Heating Equivalent Costs is small, it may take many years of fuel savings to pay for installing a new heating system. Also, remember that some fuels have incidental costs associated with them, such as cutting and splitting for firewood or annual maintenance for oil-fired equipment. Environmental damage caused by the production or use of the fuel is another cost that this chart doesn't address.

Finally, the best way to lower your heating costs is to make your home more energy efficient. Not

only will this reduce the amount of fuel you use each heating season, it will also lessen the impact of annual price fluctuations by reducing the amount of fuel you need to buy during the heating season when prices are at their peak.

Appendix D

Glossary

Air barrier: An air-impermeable material usually installed on the warm side of a building assembly, such as a wall, to stop the flow of air and its associated water vapor into the building assembly. Air barriers may be made of polyethylene plastic, drywall, rigid insulation, dense-pack cellulose insulation, or a combination of materials.

Air Changes per Hour (ACH): Measurement of the rate of natural air leakage in a building. The number of times an hour that the entire house volume of air is replaced with outside air.

Air-Leakage heat loss: The heat loss resulting from the leakage of conditioned air into and out of a building. One of the two major types of heat loss from a building, the other being **surface or transmission heat loss**.

Airtight Drywall Approach (ADA): A method of construction for moisture control and durability that uses sealed drywall as the air barrier and special interior paint as the vapor retarder.

Air-to-air heat exchanger or heat recovery ventilator: Device for supplying and partially preheating fresh outdoor air as stale indoor air is exhausted. Fan-operated.

Air/vapor barrier: A material that is used as an **air barrier** and a **vapor barrier**. In new construction, polyethylene plastic often is used as an air/vapor barrier when it is installed just to the outside of the interior finish material, such as drywall. In order for this air/vapor barrier to serve as an effective *air* barrier, the plastic must be sealed at the joints and at all penetrations, such as electrical boxes and plumbing pipes.

Backdrafting: Potentially dangerous situation in which combustion gases (from furnace, boiler, gas water heater, fireplace, etc.) exhaust into the house instead of up the chimney. Caused by negative pressure in the house—often a result of exhaust-only fans operating in a tight house or leaky return ductwork.

Backer rod: Foam “rope” that is used for sealing around wall penetrations and between framing members, and as a backing for caulk in deep cracks.

Blower door testing: Method of measuring air leakage by depressurizing a house with a large fan set into an exterior door opening. Also an excellent device for finding air leaks in the envelope of a building.

Cantilevered truss: Roof truss that overhangs the walls so that a greater thickness of insulation can be installed at the eaves.

Compact fluorescent lamp: High-efficiency fluorescent lamp that is about the same size as an incandescent light bulb. Some include integral ballasts and can be screwed into standard light bulb sockets.

Condensation: Change of state from gas to liquid. Water vapor often condenses into liquid water as an air mass is cooled.

Condensing furnace or boiler: High-efficiency heating system that extracts heat out of water vapor that would otherwise escape up the chimney. Efficiencies are usually above 90 percent.

Dew point: The temperature at which a volume of air reaches 100% relative humidity and water vapor begins condensing.

Diffuse: The process by which water vapor and other gases move through a solid as a result of vapor pressure differences. The rate of diffusion is determined by the material’s permeability (or perm rating) and the vapor pressure differentials.

Direct-vent combustion appliance (sealed combustion): A combustion appliance that 1) is vented directly to the outdoors and 2) receives all its combustion supply air directly from the outdoors through a dedicated pipe. Eliminates the possibility of **backdrafting**.

Drainage mat: A porous mat installed against the outside of a foundation wall to drain runoff away from the wall surface and down to footing drains.

Duct mastic: A special long-lasting, heat resistant material used for sealing ductwork joints. Should be used instead of duct tape.

Energy Guide labels: Labels on most new appliances providing information on yearly energy costs. Useful for comparing appliances.

Expanding foam sealant: A polyurethane foam that is applied from a can or canister. Used for sealing around windows, doors and wall penetrations.

Foam gaskets: Foam strips or rolls used to seal between framing members (under wall plates, for example), behind drywall, etc.

Heat loss coefficient: A measurement of a building’s heat loss expressed in Btu/°F hr.

Heating degree-day: A unit that represents a 1°F deviation from a fixed reference point (usually 65°) in the average daily outdoor temperature. If the average outside temperature is 45°, 20 degree-days would be tallied for that day (65° - 45°). Monthly and annual degree-day totals are obtained by adding up degree-days.

Heating outdoor design temperature: The outdoor temperature used when calculating the size of heating systems.

Heat recovery ventilator or air-to-air heat exchanger:

Device for supplying and partially preheating fresh outdoor air as stale indoor air is exhausted. Fan-operated.

House wrap: A material, usually made of spun-bonded plastic, used for covering the outside of buildings before the finished siding is installed. Acts as temporary protection from the weather until the finished siding is installed. Allows water vapor to pass through it only if it is above the **dew point temperature**.

I-Joist: A manufactured laminated wood joist that has greater strength than standard lumber. Available in greater widths and lengths than standard lumber. Sometimes used as rafters when high insulation levels are required.

Indirect-fired water heater: A storage-type water heater that uses heat from a standard boiler. Much less expensive to operate than a **tankless coil** water heater.

Magnetic declination: The difference between true north (or south) and magnetic north (or south). For solar siting, true directions should be used. If using a compass, you need to correct for the magnetic declination.

Net free vent area: Actual ventilation area provided by a screened or louvered vent—accounting for air blockage by screening and louvers.

Passive solar: A building design to collect, store and distribute solar energy without fans and pumps.

Permeance: Ability of a material to allow water vapor to diffuse through it.

Perm rating: Measurement of a material's ability to transmit water vapor by means of diffusion.

Rafter plate: Plate installed on top of ceiling joists to raise rafter tails above the wall plate and thereby allow thicker insulation at the eaves.

Raised-heel truss: A roof truss design that allows full-thickness ceiling insulation at the eaves.

R-value: Measurement of a material's ability to retard heat transfer. Inverse of U-factor ($R = 1/U$).

Relative humidity: The amount of water vapor in a sample of air divided by the maximum the sample can hold at a given temperature, expressed as a percentage.

Reset control or modulating aquastat: A control that regulates boiler water temperature relative to outside temperature. When it is not as cold out, lower-temperature water can be circulated through hot water radiators. The reset control automatically regulates the boiler water temperature.

Saturated foam sill sealer: Foam gasket impregnated with non-hardening sealant to provide highest quality sill

sealer.

Sealed combustion (direct vent): A combustion appliance that: 1) is vented directly to the outdoors, and 2) receives all its combustion supply air directly from the outdoors through a dedicated pipe. Eliminates the possibility of **backdrafting**.

Sill sealer: Foam gasket or insulation material for sealing between sill and foundation wall.

Solar sunspace: A room in a house with south-facing glass that has a means of storing and then distributing solar heat energy to the house.

Sone: A unit of loudness, as perceived by a person with normal hearing, equal to the loudness of a pure tone having a frequency of 1,000 hertz at 40 decibels. A new refrigerator runs at a loudness level of about one sone.

Splines: Wood or plywood strips for joining **structural insulated panels**.

Standpipe: Pipe set into the crushed stone before a slab is poured. Usually capped for later use in ventilating radon if a problem shows up.

Stepped insulation: Foundation insulation strategy where full-thickness insulation is used over the upper part of the wall, and thinner insulation is used below.

Structural Insulated Panel System (SIPS): Building panels for enclosing timber frame buildings or for building "frameless" houses. Laminated system with exterior sheathing, insulation and inner wall surface.

Sun angle: Angle of the sun above horizon as it moves across the sky. Used in designing solar heating systems.

Suntempering: Simple passive solar design utilizing moderate areas of south-facing glass. There are no special measures taken to store and distribute solar heat.

Surface or transmission heat transfer: The transfer of heat energy from one material to another by the motion of adjacent atoms and molecules.

Tankless coil: Inefficient type of water heater operating off a boiler. As hot water is used, the boiler must fire to heat it. Particularly wasteful in the summer when space heating is not required.

Timber frame construction: Construction technique in which large timbers are used to provide structural strength in a building.

Thermal mass: Masonry or other material for storing heat in a passive solar heating system.

U-factor: Measurement of the heat transmission through a building assembly in Btu/°F, hr. Inverse of R-value ($U = 1/R$).

Vent spacer, vent chute or "proper vent": A spacer made of cardboard or beadboard intended to keep insulation away from the underside of roof sheathing so as to provide an airway for roof ventilation.

Vented rain screen: Air space provided by strapping between sheathing and siding to allow for pressure equalization as a mean of preventing driving rain from penetrating the innermost components of a wall. Vinyl siding, with its open-back profile, provides it own vented rain screen area.

Vapor barrier: A material—usually polyethylene or foil— for preventing or slowing the movement of water vapor by means of diffusion. Usually installed on inner (warm) side of insulation. Has a permeance value of 0.1 or less.

Vapor retarder: A material—usually kraft paper or paint— for slowing the movement of water vapor by means of diffusion. Usually nestled on inner (warm) side of insulation. Has a permeance value greater than 0.1.

Water table trim: Trim used at the bottom of a wall to shed water out and over protruding foundation insulation.

Wet-spray cellulose: Type of insulation that is sprayed into open wall cavities. Somewhat higher R-value than fiberglass and better at sealing around wires, etc.

Window insulation: Soft insulating shades or rigid insulating shutters (unusually mounted on the interior) that can be closed to: 1) increase the insulating value of window, or 2) to block unwanted solar heat gain. These products are made especially for this purpose.

Zones: Separately controlled conditioned areas in a building, each controlled by its own thermostat.

Appendix E

For More Information

References

Periodicals

Energy Design Update
Aspen Publishers, Inc.
1185 Avenue of Americas
New York, NY 10036
(800) 638-8437
www.aspenpublishers.com
Monthly newsletter featuring energy-efficient materials and techniques.

Fine Homebuilding
The Taunton Press
63 South Main Street
P.O. Box 5506
Newtown, CT 06470-5506
(203) 426-8171
www.taunton.com/finehomebuilding
Monthly magazine with a mix of practical and esoteric construction articles.

Home Energy Magazine
2124 Kittredge, Suite 95
Berkeley, CA 94704
(510) 524-5405
www.homeenergy.org
Bimonthly magazine for energy conservation professionals.

Journal of Light Construction
186 Allen Brook Lane
Williston, VT 05495
Phone: (802) 879-3335
www.jlconline.com
Monthly publication featuring discussion of practical residential construction problems and techniques.

Books

Building Foundation Design Handbook
Underground Space Center, Univ. of Minnesota, 1989
500 Pillsbury Drive, SE
Minneapolis, MN 55455
The most complete reference available on foundation design and construction.

Builder's Guide to Cold Climates
Joe Lstiburek, Building Science Corp.
Energy & Environmental Building Association
10740 Lyndale Avenue South, Suite 10 West
Minneapolis, MN 55420
(952) 881-1098
www.eeba.org
Good, well illustrated guide for new construction.

The Passive Solar Energy Book
E. Mazria
Rodale Press, 1979
Emmaus, PA 18099-0017
Although dated, it's still the most comprehensive book on incorporating solar heating with building design.

Modern Carpentry
Willis H. Wagner
Goodhardt
123 West Taft Drive
South Holland, IL 60473
Comprehensive carpentry text.

Residential Load Calculation: Manual J, 7th edition
Air Conditioning Contractors of America
2800 Shirlington Road, Suite 300,
Arlington, VA 22206
(703) 575-4477
www.acca.org

Residential Duct Systems
Air Conditioning Contractors of America
2800 Shirlington Road, Suite 300,
Arlington, VA 22206
(703) 575-4477
www.acca.org

International Energy Conservation Code (IECC), 2003
International Code Council
5203 Leesburg Pike, Suite 600
Falls Church, VA 22041
(800) 786-4452
www.iccsafe.org
The IECC is the most recognized energy-efficiency building code. It has taken the place of the Model Energy Code (MEC).

Web Sites

In addition to those already listed in this Reference section, the following are recommended.

American Council for an Energy-Efficient Economy
www.aceee.org
Listings of the most energy-efficient appliances and office equipment.

Building America
www.eere.energy.gov/buildings/building_america/
Building America works with members of the home-building industry to produce quality homes that use less energy without costing more to build.

Energy & Environmental Building Association
www.eeba.org
Good information and a great online bookstore.

Energy Star
www.energystar.gov
Energy Star appliance listings and programs.

Gas Appliance Manufacturers Association (GAMA)
www.gamanet.org
Listing of the efficiencies of gas- and oil-fired furnaces and boiler efficiencies and output rates, as well as listing of electric, gas, and oil water heater efficiencies.

US Green Building Council
www.usgbc.org
The place to begin for green building design and news. Information about LEED certification and other green building programs.

Appendix F

The Performance or Tradeoff Method of Compliance with REScheck

The easiest method of compliance with the Maine Energy Efficiency Standards is by using the prescriptive approach discussed in Part 1 of this manual. This method prescribes the required R-values for the various building parts. For example, a house complies by the prescriptive standard if it has R-49 ceilings, R-21 walls and floors, and U-0.4 windows.

A more flexible approach to compliance is available by using the performance compliance or trade-off approach. This approach is made easy with the use of the free REScheck software. This free software can be downloaded safely at <http://www.energycodes.gov/rescheck>. If you use this software, make sure you enter "2003 IECC" as the code, enter "Maine" as the state, and enter the city closest to your building site.

REScheck allows the user to alter the R-values of walls, floors, roofs/ceilings, and doors; select different window U-factors; and select a heating system for compliance. If the selected R-values, U-factors, and efficiency do not comply, the user can simply alter any of the details to see the immediate result.

A designer can quickly find a number of alternatives of compliance for a particular house. For example, one alternative for compliance might include R-38 ceilings, R-19 walls, and a heating system with an 84 percent efficiency. Another alternative for the same house might include R-49 ceilings, R-21 walls, and a heating system with an 80 percent efficiency. With this trade-off approach, one component or piece of equipment must be made more energy efficient if another is made less energy efficient. The software does all the complex calculations.

After the preferred design is found, REScheck will print a report listing the details of the energy characteristics and the percent by which it exceeds the 2003 IECC.

The software also includes a feature for calculating surface areas of windows, doors,

walls, ceilings, and floors. These calculated areas with their corresponding insulating values can then be added to a library for use with other similar house designs.

Another option is to use REScheck-Web, a web based version of REScheck (go to <http://energycode.pnl.gov/REScheckWeb>). If you use this web version, make sure you enter "2003 IECC" for the code and "Maine" for the state. This Web-based version is almost exactly the same as REScheck run on a computer.

Finally, another option offered on the Web is REScheck Package Generator (go to <http://energycode.pnl.gov/REScheckPkgGen>). By entering the component R-values and window U-factors, this program will generate packages that are in compliance with the 2003 IECC, the basis for the Maine Model Building Energy Code.